

barduva 

GRB60

Inclined platform lift



MADE IN EU

GRB60

Inclined Platform Lift

GRB60 inclined platform lift is a safe and convenient option for people with mobility impairments to move up and down stairs. They are relatively inexpensive and can be used in both homes and businesses. This lift travels in a straight line up and down the stairs.

FEATURES

- Mechanical sensor under the platform
- Limit switch
- Overspeed sensor
- Weight sensor
- Manual emergency arm lift
- Manual release mechanism
- Manual emergency transport of the lift to one of the exit platforms
- Strips with mechanical sensors on the sides of the lift body
- Platform access ramps with mechanical sensors (when the lift is in motion)
- Emergency stop button

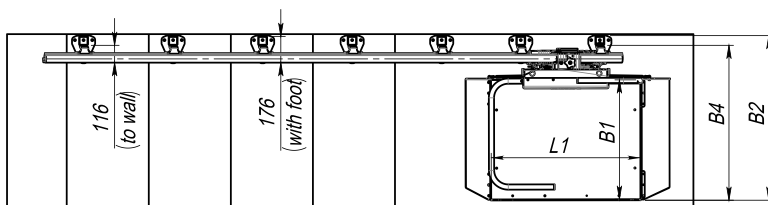
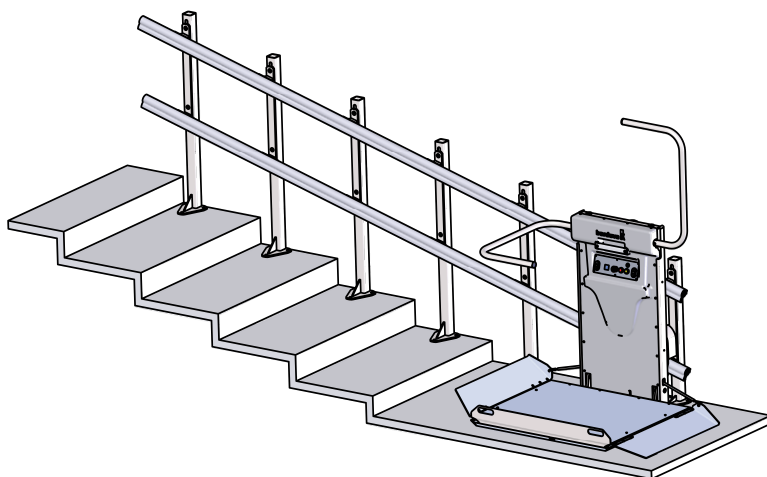

Specifications

Load: 225 kg

Travel: 3000 mm Up to 30 m (depending on rail inclination angle)

Speed: *0,1 m/s (reduced in the curves)

Driving motor: 0,5 kW

Platform motor: 24 V

Barrier-arm motor: 24 V

Power supply: by batteries

Voltage: 24 V DC; for recharger 1 x 230 V

Lift: 24V DC

Driving mechanism: Rack and Pinion (safety - overspeed governor)

Construction: Steel-and aluminium rails on

Platform standard size: 1000 x 800 mm

Other sizes: Length x Width in mm
750x700; 850x700; 1250x800



Barduva, JSC

Beržuonos str. 2, LT-02121 Vilnius, Lithuania

00 370 5 231 0770 (Phone)

sales@barduva.eu

www.barduva.eu