

# **USER AND MAINTENANCE MANUAL**

## **Vertical lifting platform AB300**

**Manufacturer** BARDUVA, JSC  
Beržuonos str. 2  
LT-02121, Vilnius  
Lithuania  
Tel. +370 5231 0770  
Fax. +370 5231 0773  
E-mail. sales@barduva.eu  
www.barduva.eu

**Service line** Tel. +370 5231 0770  
E-mail. support@barduva.eu

**Date of issue** 2022-02-02

**Author** GP

**Release** 1.0/22-02

**Revision** 3

**Doc. No.** AB300-USER-EN-1

**Copyright** © - Barduva, 2022

No part of this publication may be reproduced,  
distributed or made available to the public without the  
written permission of JSC Barduva

## Revisions overview

<b>Revision No.:</b>	<b>Date</b>	<b>Summary of revision</b>
-	02-02-2022	Original
1	10-10-2022	6.5. Emergency unlocking of stop-landings 7.5. Belts 8.5. The main power switch 10. Labels (icons), text warnings 12. Release of passengers 13.8. Scope of maintenance operations
2	24-10-2022	10. Labels (icons), text warnings 12. Emergency manual operation
3	11-01-2023	6.5. Emergency unlocking of stop-landings 12.3. Emergency mode activation

# CONTENTS

INTRODUCTION	4
TERMS AND DEFINITIONS	4
GENERAL SAFETY REQUIREMENTS	6
INFORMATION FOR LIFTING PLATFORM OWNER	7
DESCRIPTION OF SAFETY DEVICES	15
OTHER SAFETY DEVICES	16
AB300 CONTROLLERS	18
POWER SUPPLY	22
PLATFORM OPERATE MODES	24
LABELS (ICONS), TEXT WARNINGS	23
SAFE USE OF THE LIFTING PLATFORM	26
EMERGENCY MANUAL OPERATION	28
LIFTING PLATFORM MAINTENANCE	31
SPECIAL TOOLS	36
SAMPLE EC DECLARATION OF CONFORMITY	37
VERTICAL LIFTING PLATFORM MAINTENANCE LOGBOOK	38

## INTRODUCTION

The manual describes an operation of a lifting platform AB300, lifting platform maintenance, and the lifting platform owner's responsibility to ensure the safe and reliable operation of the lifting platform.

Before using the lifting platform, carefully read this User and maintenance manual of the lifting platform.

This manual is intended for the owner of the lifting platform and for the maintenance service.

This manual must be stored during the entire service life of the lifting platform.

## TERMS AND DEFINITIONS

**Maintenance** means all operations necessary to ensure that, after installation, the lifting platform and its components function safely as intended, throughout the entire service life.

### Maintenance consists of:

- 1 visual inspection, lubrication, cleaning, etc.;
- note: cleaning operations are not included in the maintenance operations: 1) cleaning of external enclosure of the lifting platform; 2) cleaning the inside of the platform.
- 2 tests;
- 3 passenger rescue operations;
- 4 adjustment and tuning operations;
- 5 repair or replacement of components not detrimental to the characteristics of the lifting platform, which may be necessary due to deterioration or wear.

### Maintenance operations do not include the following operations:

- 1 replacement of the main components such as drive, platform, controls etc., or safety components such as safety devices, etc., even if the locations of replacement components are the same as for the original components;
- 2 replacement of the lifting platform;
- 3 modernization of the lifting platform, including changes to any of its characteristics (such as speed, load, etc.);
- 4 rescue operations carried on by fire brigade.

**Maintenance service** means the company or a business unit with a competent maintenance worker(s) performing maintenance operations in the name of the lifting platform owner.

**Competent maintenance person** means a duly trained and appointed person having necessary knowledge and practical experience, equipped with necessary instructions and having the assistance of the maintenance service, whose task is to provide conditions for proper and safe performance of certain maintenance operations.

**Manufacturer** means a natural or legal person who assumes responsibility for the design, production and marketing of the lifting platform.

**Contractor** means a natural or legal person who assumes responsibility for the installation and placing on the market of the lifting platform.

**Lifting platform owner** means a natural or legal person, who has the power to dispose the lifting platform and assumes responsibility for its operation and use.

**Emergency service** means the organization responsible for the receipt of the alarm information and release of passengers entrapped in the lifting platform. Emergency service may be part of the maintenance service.

**Rescue actions** mean actions initiated upon receipt of a notification of the passenger (s) entrapped in the lifting platform and completed upon release of the passenger (s) entrapped.

**Passenger** means a person who uses the lifting platform.



**Maintenance logbook** means a book containing all the necessary information related to the lifting platform, and providing sufficient space to make records of inspections, tests, and any repairs or modifications.

## GENERAL SAFETY REQUIREMENTS

This section describes the general safety requirements that must be complied with when using the lifting platform and performing the maintenance of the lifting platform in order to avoid danger to life, health and property.

### 3.1. Symbols

Meaning of symbols used in the manual:

Symbol	Potential consequences and measures to avoid danger
 Warning!	This symbol indicates a high level of injury. Failure to apply protective measures may result in a risk of fatal or irreparable damage to the lifting platform!
 Attention!	This symbol indicates the average level of injury. Failure to apply protective measures may result in severe injuries or damage to the lifting platform!
 Dangerous!	This symbol indicates a low level of injury. Failure to apply protective measures may result in minor injuries or damage to the lifting platform!

### 3.2. Application of the lifting platform

The lifting platform is designed for transportation of passengers with impaired mobility, as well as passengers in wheelchairs, with or without a companion, to the specified floor.

The lifting platform owner must ensure that the lifting platform is used only for the intended purpose.

### 3.3. Passenger and competent person qualifications

Passenger qualification.

Lifting platform passengers require no additional preparation or training to use the lifting platform.

Passengers who cannot use the lifting platform controls and (or) to get on the platform independently for certain reasons, can use the lifting platform only with the accompanying person.

### **3.4. Qualification of competent maintenance personnel**

Maintenance of the lifting platform requires mechanical and electrical skills as well as practical experience.

The competent maintenance personnel must have the necessary mechanical and electrical training and practical experience in the form the required maintenance operations in a safe and proper manner.

### **3.5. Maintenance**

Maintenance must be carried out in accordance with this manual and the Maintenance manual of the vertical lifting platform.

Safety and service life of the lifting platform depends on timely and periodical maintenance of the lifting platform.

Personal protective equipment is essential and mandatory during the maintenance of the lifting platform.

### **3.6. National legislation**

In addition to this manual, it is necessary to observe all legislation of the country in which the lifting platform will be used, establishing the requirements for use, maintenance, safety and health, and environmental protection.

### **3.7. Modification and repair**

Any modifications of the lifting platform or its components must be approved by the manufacturer, otherwise the guarantee and declaration of conformity of the lifting platform becomes void.

Broken parts of the lifting platform must be replaced with new original parts of the manufacturer. The use of components of the lifting platform other than original is not allowed! It is necessary to organize the delivery of spare parts for repair. Only original parts must be used for repairs of the lifting platform.

## **INFORMATION FOR LIFTING PLATFORM OWNER**

The lifting platform owner must ensure that the lifting platform is used only for its intended purpose (the purpose of the lifting platform is indicated in chapter 3.2).

If the lifting platform is used not according to its purpose, it may result in dangerous situations with the likelihood of injuries or damage to the lifting platform.

Only suitable and preventative maintenance performed by the competent service personnel in accordance with this manual can provide safe functioning of the lifting platform.

The lifting platform owner must operate the lifting platform in accordance with safe operating conditions. For this, the lifting platform owner must use the maintenance service.

The lifting platform maintenance must be performed in accordance with the Maintenance manual of the vertical lifting platform, and the national legislation of the country in which the lifting platform is operated.

It is necessary to ensure that the periodic maintenance of the lifting platform is performed by the maintenance service no later than the lifting platform is put into operation.

The lifting platform owner must discontinue the operation of the lifting platform in the event of a dangerous situation.

In case of lifting platform failures, in particular, the failures that affect the safety of passengers, the operation of the lifting platform is prohibited. The lifting platform owner must ensure that in case of failures the lifting platform is disconnected and passengers cannot use it.

**The lifting platform owner must inform the lifting platform maintenance service:**

- 1 immediately, upon noticing any incorrect operation of the lifting platform, failure or abnormal change in its immediate environment;
- 2 immediately, about the termination of operation of the lifting platform in the event of a dangerous situation;
- 3 after intervention of any authorized and trained person (s) of the rescue service;
- 4 before any modification relating to the use of the lifting platform, and (or) its environment;
- 5 before any sanctioned third-party verification or work, other than the ongoing maintenance of the lifting platform;
- 6 prior to long-term termination of operation of the lifting platform;
- 7 before returning the lifting platform to service after a long period of inactivity.

The lifting platform owner must ensure the availability of the maintenance service name and telephone number for the lifting platform passenger at all times. The number must be permanently affixed and clearly visible.

The lifting platform owner must ensure that the keys to the machine cabinet, stop-landing doors are always available in the building and for the maintenance service or authorized personnel.

The lifting platform owner must take care that the maintenance service, participating in the rescue of passengers, under any circumstances can safely enter the building and have access to the lifting platform.

The lifting platform owner must provide the competent staff of the maintenance service the safe and free access to the operational areas and notify the maintenance service of any hazards or changes in the entrances to the operational and (or) entrance walkways.

**In addition to inspections and tests carried out by the maintenance service, for the benefit of its interests, the lifting platform owner must periodically carry out the following tasks:**

- 1 Movement quality assessment: Raising the platform from the lower stop-landing to the upper stop-landing and lowering it from the upper stop-landing to the lower stop-landing;
- 2 Platform enclosure: Checking whether the platform enclosure shows any signs of mechanical damage
- 3 Stop-landing door:
  - 3.a Checking whether the stop-landing door shows any signs of mechanical damage
  - 3.b Checking whether the stop-landing door opens and closes properly
  - 3.c Checking whether the stop-landing door cannot be opened if the platform is not in the stop-landing
  - 3.d Checking whether the platform cannot move if the stop-landing door is opened
- 4 Electrical stop-landing door opening and closing device (for stop-landing doors with an electric opening and closing drive): Checking whether the delay time of the stop-landing door is right (only for the stop-landing door with an electric opening and closing drive). The delay time of the stop-landing door must be set from 2 seconds to 20 seconds
- 5 Platform stopping accuracy between the platform and the stop-landing thresholds: Acceptable accuracy of the platform stopping in the landings. The platform stop accuracy must not exceed  $\pm 10$  mm.
- 6 Platform call buttons in the stop-landing: Checking for proper functioning of the platform call button in the stop-landing
- 7 Control devices located on the platform: Checking for proper functioning of the platform controls for controlling the platform movement direction
- 8 Emergency stop device on the platform: Checking for proper functioning of the emergency stop device. The platform must immediately stop upon pressing the emergency stop device
- 9 Remote alarm system: Checking for proper functioning of the remote alarm system
- 10 Reliability of closure of the machinery cover located on the platform: Checking for proper closure of the machinery cover
- 11 Safety markings and other markings: Checking whether the maintenance service name and phone number are indicated on the platform.

### 5.1. Enclosure of the lifting platform

The lifting platform enclosure is made up of separate interconnected panels. The lifting platform enclosure panels are made of tempered laminated glass or tin. Panel frames are made of anodised aluminium.



Lifting platform enclosure

The lifting platform enclosure is attached to the building structures with bolted connections. Depending on the place of installation of lifting platform, the lifting platform stability is ensured by using the reinforcing bracket to the lifting platform enclosure. The bracket is bolted to the lifting platform enclosure and the building structures.

### 5.2. Machinery cabinet

The machinery cabinet is located in the lower either the upper stop near the stop-landing door. The machinery cabinet is included in the electrical equipment of the lifting platform (power cable, power disconnection device, etc.), emergency equipment etc.

AB300 additionally has a Base unit board, 24 V DC power supply unit, Safety relay unit, electric emergency lowering power module (option), telephone line module GSM GL1 (option) and cable from the platform connected to the Base unit board.

### 5.3. Stop-landing door

Each stop-landing area has the “Landing door controller”. The stop-landing door opening/closing gear may be power operated.

#### Stop-landing door with manual operation (standard):

The stop-landing door with a mechanical drive is opened by hand, and closed automatically by hydraulic closer.

#### Electromagnetic opened stop-landing door holder (optional):

The electromagnetic opened stop-landing door holder for doors with mechanical drive ensures that, when the door is fully open, it will stay in the fully open position for the specified delay time, till

closure, or until the platform direction control button is pressed. After a pre-set delay closing time or after pressing the platform direction control button on the platform, the stop-landing door starts closing automatically. When the stop-landing door stops and the platform direction control button is pressed, the platform begins to move. When the platform stops in the stop-landing, the stop-landing door is opened manually.

Stop-landing door with electrically operated opener&closer (optional):

The stop-landing door with electric drive is opened and closed automatically.

When the platform call button in the stop-landing is pressed, the stop-landing door opens automatically and stays open for a maximum of 30 seconds. Pressing the platform movement direction control button on the platform, the stop-landing door starts closing automatically. When the platform direction control button is released during the stop-landing door closing, the door will begin to open automatically. When the stop-landing door stops and the platform direction control button is pressed, the platform begins to move. When the platform stops in the stop-landing, the stop-landing door is opened automatically.

**NOTE:** In order to enable passengers to easily climb on and off the platform, the initial delay time of the stop-landing door is set to 5 seconds. The control system can be used for adjusting the delay time of the stop-landing door from 2 seconds to 20 seconds. The adjustment tools are not available to passengers. The delay time of the stop-landing door can only be adjusted by the competent maintenance personnel.

**5.4. Machine**

The belt drive system is used for the platform movement. The guide rails and machine compartment are integrated with the lift well structure. An electric motor transmits the rotary motion via the belt drive to the platform.

**5.5. Lifting platform controls and indicators, and the control panel**

Platform travel direction control buttons are of forced type of operation. In order for the platform to travel to the selected stop-landing, the platform moving direction control button must be pressed constantly. Upon releasing the button, the platform stops automatically. When the platform arrives at the selected stop-landing, the platform stops automatically.

The platform travel direction control button takes precedence over the platform call buttons in the stop-landing.

The platform travel direction control buttons are marked with the following figures: -1, 0, 1, 2, 3, etc.









**5.6. Platform movement direction indicator (optional)**

The platform travel direction indicator shows the direction of the platform travel, or the number of the stop-landing, in which the platform as stopped.

The indicator can also be mounted in the buttons, and display the floor number, in which the platform is (optional).



**5.7. Platform call button**

Standard version call button			
MC version call button			
	Call button in the intermediate stop	Call button in the initial stop	Call button in the highest stop

Each stop-landing is equipped with a platform call button to call up the platform to the stop-landing.

**NOTE:** Platform travel direction control buttons located on the platform take precedence over the platform call buttons in the stop-landing.

To call up the platform to the stop-landing, press and release the platform call button in the stop-landing (2).

The platform call button can be activated using the programmable key or standard lock with key (optional).

The platform call button may have an indicator (3), indicating the floor in which the platform is. If unit is ordered with MC type call buttons, indicator is integrated in to door frame. (optional)

Also, the platform call button in the stop-landing informs about the platform status. LED built in the button (1).

### Interpretation of indicator lights

LED state	AB300
No lights	Unoccupied platform, the passenger can call the platform to the stop-landing
Red light flashing or constantly on	The platform is busy
Green light flashing	The platform is coming to the stop-landing from which the call signal was received

#### 5.8. Lighting

**Illumination of platform controls.** Platform controls are illuminated with light-emitting diodes (LED) on the platform. LED turns on automatically after activating one of the platform controls on the platform or on the stop-landing. The initial delay time of the lighting of controls is set for 2 minutes. When 2 minutes pass after the platform use, the LED backlight turns off automatically. The control system can adjust the delay time of the LED lighting. Adjustment tools are not available to passengers. LED lighting delay time can be adjusted by a competent maintenance person.

**Emergency platform illumination.** Platform controls LED lighting also performs the emergency platform lighting function. Emergency platform lighting is activated automatically upon shutdown of the normal lighting and is powered for at least 1 hour. Emergency platform lighting is powered automatically from a rechargeable battery in the platform.

**Enclosure illumination (optional).** Enclosure can be illuminated by lights, fitted at the top of the enclosure. The enclosure lighting duration was set for 2 minutes. After 2 minutes from the platform use, the enclosure lighting turns off automatically. The control system can adjust the enclosure lighting delay. Adjustment tools are not available to passengers. Enclosure lighting delay time can be adjusted only by a competent maintenance person.



## DESCRIPTION OF SAFETY DEVICES

### 6.1. Emergency platform stop device

The emergency stop device is intended to stop the movement of the platform in the event of a dangerous situation.

By pressing the emergency stop button the indicator in the emergency braking device lights up notifying of the activation of the emergency stop device. The emergency stop device is of non-forced operation type, i.e., when pressed, the emergency stop device automatically locks in the pressed position.

In order to use the platform again, the pressed emergency stop device must be rotated clockwise. Normal platform control is restored in 5 or 40 seconds (the indicated time depends on the frequency converter type installed in the lifting platform) after the reset of the emergency stop device.



**NOTE:** If the platform does not start moving after pressing the platform travel direction controller, or if the platform suddenly stops, always make sure that the platform emergency stop device is not pressed.

### 6.2. Emergency alarm device

The emergency alarm device is used for calling external help for the passengers on the platform, in case of the lifting platform malfunction.

When the platform stops between the stop-landings, or if the platform is in the stop-landing, but the stop-landing door does not open, the passenger must push the emergency alarm device to call for help.

In case of power failure, the emergency alarm device is powered from the emergency power supply source (battery) mounted in the bottom of the shaft.



### Emergency alarm options:

- **Audible alarm system.** If the emergency alarm button is pressed, an audible signal is emitted
- **Telephone system (optional)** The telephone system (handset) is connected to the public telephone network. When the handset is lifted, the emergency service number is dialed or speed dial number is pressed. It is programmed to automatically dial the emergency service number.
- **Remote alarm system (optional).** In order to call the outside help, the remote alarm system is equipped in the platform for passengers. The remote alarm system enables mutual conversations and maintaining constant contact with the emergency service.

If the emergency alarm device pressed, an audible alarm sound. The emergency alarm button should be pressed down for 10 seconds. After 10 seconds the remote alarm system starts the dialling and calling the programmed number. During the connection, the yellow indicator lights up and the green indicator flashes occasionally. After the connection, the green indicator lights up – continue the conversation with the operator.

### 6.3. Platform overload indicator

If the platform rated load is in excess of 75 kg, the platform overload indicator is activated with an audible and a visual signal, the red signal light, informing about the platform overload. In case of overload, the stop-landing door remains unlocked. Landing door with an electric drive remains open.

### 6.4. Indicator of safety device activation

When at least one of the safety devices in the lifting platform is activated during the platform movement, the platform movement is immediately stopped. Indication LED's of tripped safety circuit switch is shown on Base unit pcb. If the safety device is activated, check whether the platform emergency stop device is not pressed, or at least one sensitive platform edge is not pressed.

Normal platform control is restored in 5 or 40 seconds (the indicated time depends on the frequency converter type installed in the lifting platform) from the safety device activation/reset of its functions, or when the blue signal of the safety device is off.

### 6.5. Emergency unlocking of landing doors

In an emergency situation to release the passengers, the landing door can be unlocked from the outside (as well as from the inside) with a special triangular key.

When the door was opened in an emergency way using the triangular key, the lift becomes inoperable. It is necessary to reboot the control system to return it to normal operation mode. For that purpose open panel of the electrical control compartment and press and hold the button "SERV" on the base unit board until the system goes into service mode. After that, it is needed to press and hold the button "AUTO" until the system switches to auto (normal) operation mode. The lift will become operational.



When carrying out maintenance work and being under the platform inside the shaft at the lower landing, if the door slams shut, you can free yourself by using the escape rope laid on the floor.

**NOTE:** After the emergency stop-landing door opening, no tools are required for the door closing and locking.

## OTHER SAFETY DEVICES

- Stop-landing door lock and closing control safety device;
- Emergency platform stop devices;
- Pressure-sensitive edges;
- Platform limit switches;
- Electrical control safety device for the lid closing of the platform mechanisms;
- Platform mechanical stop and electric safety device;

### 7.1. Stop-landing door lock and closing control safety device

The stop-landing door is mechanically locked by the door lock that prevents opening of the stop-landing door when the platform is not in the stop-landing. The stop-landing door lock is controlled by the electric safety device.

The stop-landing door closing is controlled by the electric safety device. It is impossible to run the platform and continue its travel if the stop-landing door is open.

### 7.2. Emergency platform stop devices

The emergency stop device on the platform is designed to stop the movement of the platform in the event of a dangerous situation. (see 6.1. paragraph).

### 7.3. Pressure-sensitive edges

In order to avoid the danger of crushing the limbs and (or) objects, pressure sensitive edges are equipped around the edges of the platform. After activation (pressing) of the sensitive edge at any point, the power supply to the engine and the brakes is interrupted. The platform must stop immediately.

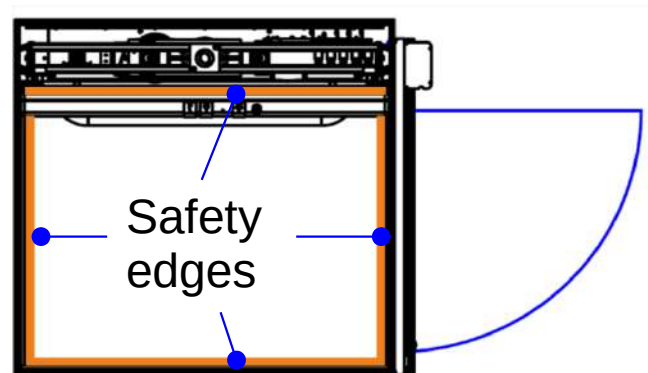

### 7.4. Platform limit switches

The lifting platform is equipped with limit switches. The limit switches are installed in such a way that they are activated when the platform passes the end stop-landings. When the limit switches are triggered, the power supply to the engine and the brakes is interrupted. The platform must stop immediately.

### 7.5. Electrical control safety device for the lid closing of the platform mechanisms

The platform mechanism cover closing is controlled by an electric safety device. It is not possible to use the platform, or change the travel direction, when the platform mechanism cover is opened.

### 7.6. Platform mechanical stop and the electrical safety device that controls the setting of the platform mechanical stop to the operating position



The manual activated platform mechanical limit switch is equipped in the platform enclosure. It keeps the platform in the open position, and provides at least 500 mm free space between the enclosure floor and the lowest parts of the platform. The platform mechanical limit switch can be set to the operating position manually from the machinery cabinet.

Setting of the platform mechanical limit switch to the operation position is controlled by an electric safety device which cuts off the power supply to the electric motor and the brake. The platform should stop immediately, and the platform use becomes impossible.

# AB300 CONTROLLERS

## BASE CONTROLLER

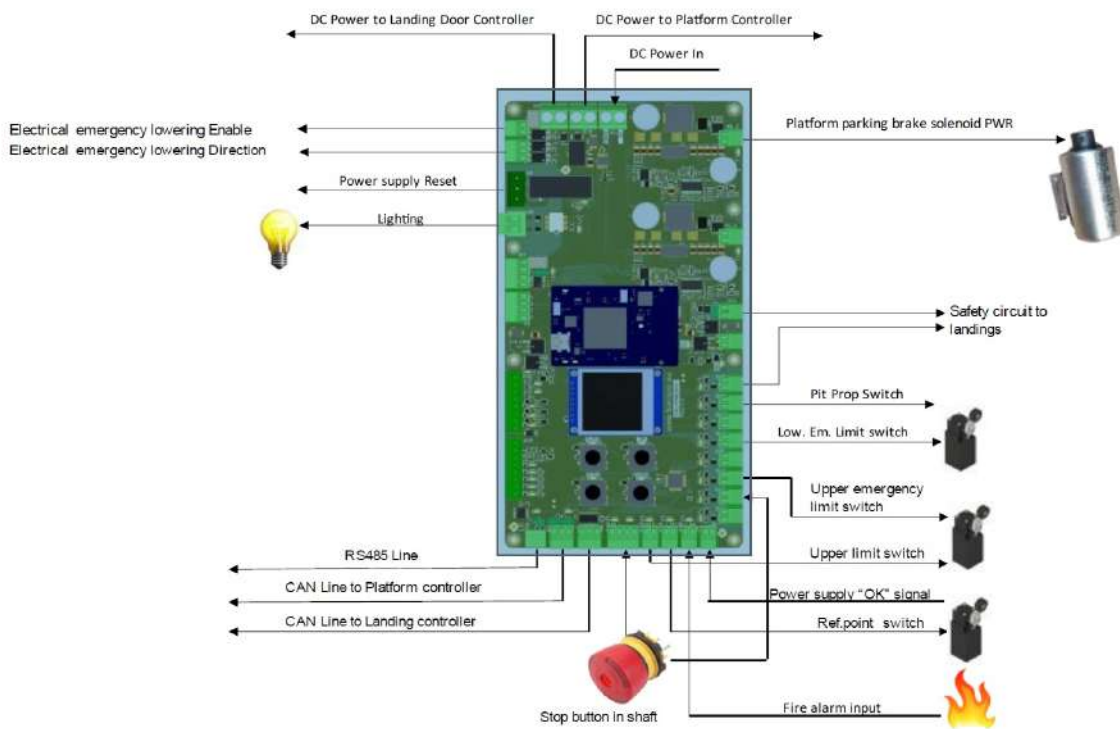

## PLATFORM CONTROLLER

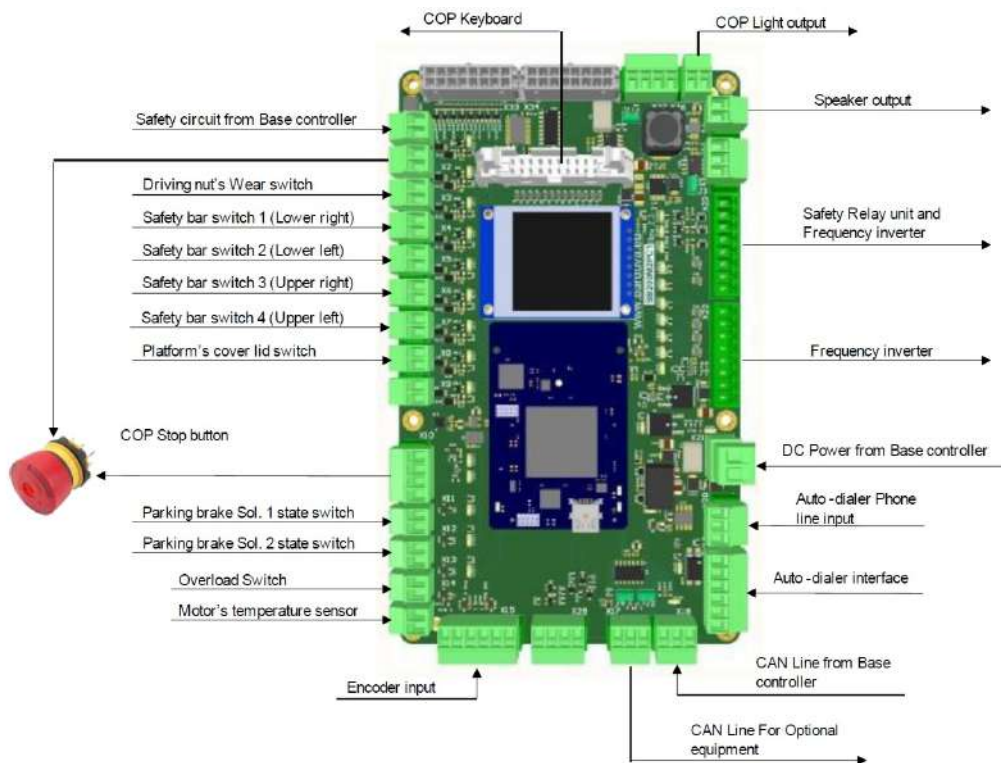

## SAFETY RELAY UNIT

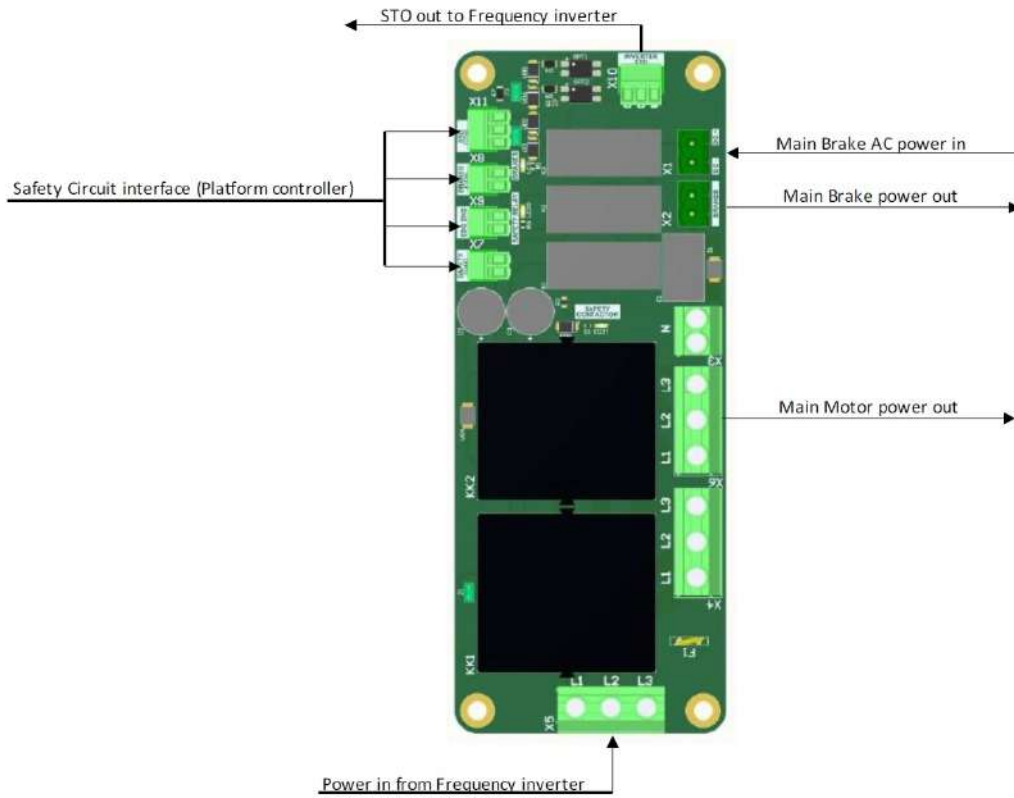

## LANDING CONTROLLER

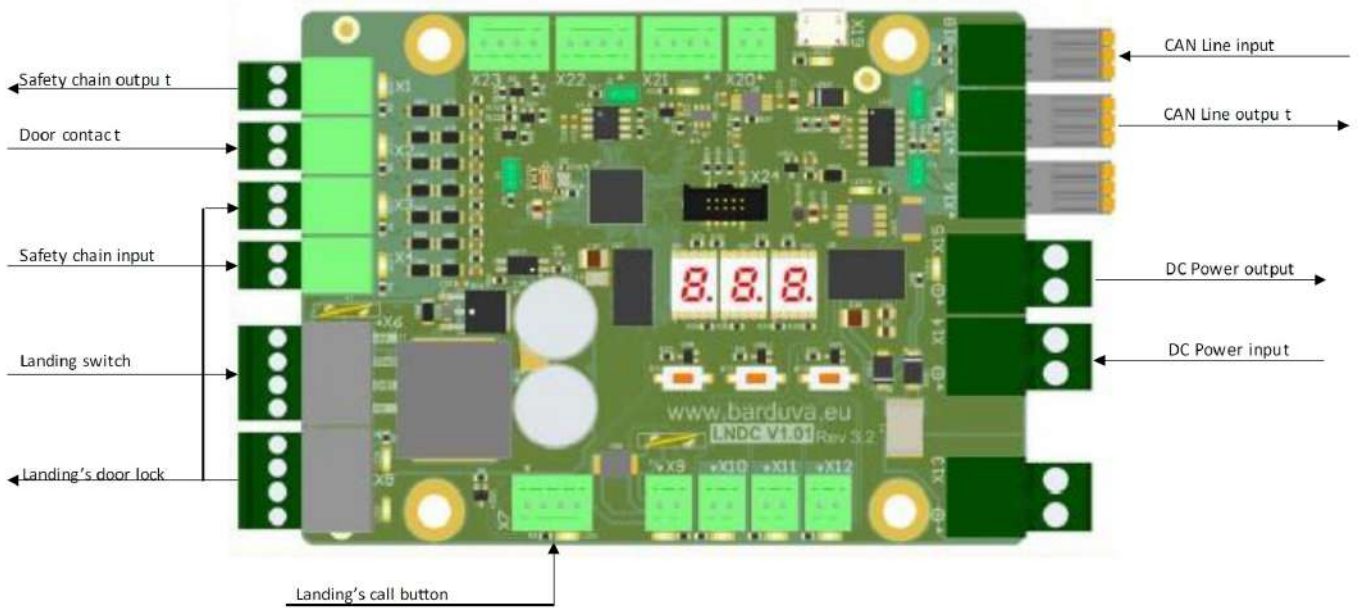

## ALL CONTROLLERS CONNECTION VISUALIZATION

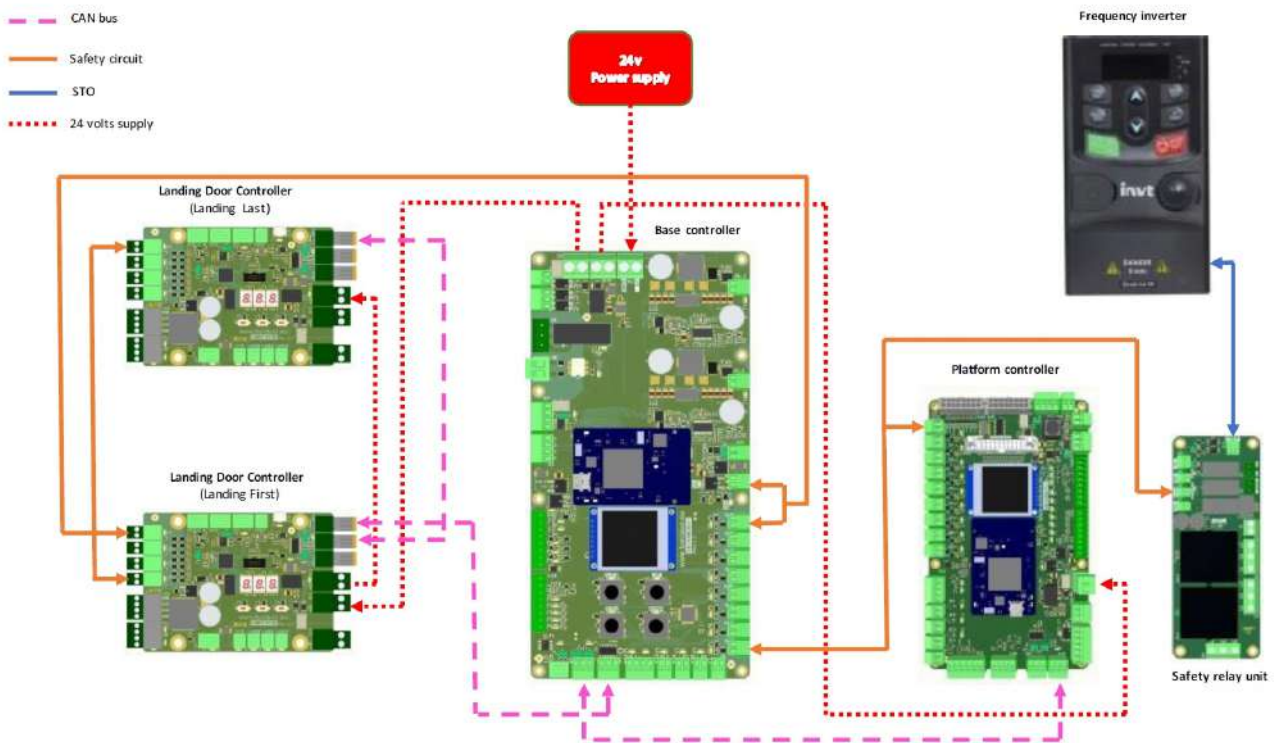

## POWER SUPPLY

There are using two types of power supply to the system in order to ensure functioning of the platform.

There are stationary power one phase 230 V AC or three phases 380 V AC 50 / 60 Hz and batteries backup power 24 V DC. System grounding is necessary!

As backup power is using batteries. Power source is 24 V.

### 8.1. Turning the power ON

Turn the power ON always in such way:

- 1 turn ON the main power breaker CB1 located in the machinery cabinet (see paragraph 8.5);
- 2 turn ON backup power. Connect fuse F1 (see paragraph 8.6).

### 8.2. Initialisation and calibration

Just the power turned on or after it restart the platform starts initialisation, later calibration.

In few seconds after main power turned on it starts initialisation. After successful start of the system there turn on emergency light on platform and light in the shaft if it is available. If safety circuit are restored, the platform starts to search "reference" point. If the platform is at higher than ground floor landing level, the platform drives down automatically itself. It stops when achieve "reference" point level. In case of the platform is at the landing level calibration will be done

without platform moving. After successful calibration ground floor door call button lights up. The platform is ready to use.

### 8.3. Turning the power OFF

Turn the power OFF always in such way:

- 1 turn OFF the main power breaker CB1, located in the machinery cabinet (see paragraph 8.5);
- 2 turn OFF the backup power. Disconnect fuse F1 (see paragraph 8.6).

### 8.4. Restarting the power

The power restarting is necessary to return the platform back to normal operation after some events or errors.

That may be the frequency inverter errors, maintenance works and others.

**The power restarting must be done in such order:**

- 1 turn OFF the power (see paragraph 8.3.);
- 2 wait at least of 40 seconds;
- 3 turn ON the power (see paragraph 8.1.).

### 8.5. The main power switch

- Remove the cover from machinery cabinet;



- turn On or OFF the main breaker;
- The main switch turns off the neutral and power supply from the UPS.

### 8.6. The backup power

Platform lift has UPS backup power supply. It is situated on base frame behind inside „B“ wall panels. And connected to the system through F1 fuse. To switch OFF backup power open and remove the cover from machinery cabinet and disconnect F1 fuse.

## PLATFORM OPERATE MODES

There are a few operate modes: normal, maintenance / service (installation), blocked, electric emergency lowering and alarm.

### 9.1. Normal mode

Mode is dedicated for users to use the platform in normal conditions. There is all function mentioned in the manual. The platform movement speed is 0,15 meters per second.

AB300 platform is in “**Normal mode**” if there is a red light indication above black button **AUTO** on the base unit board in the machinery cabinet. How to change the mode is explained in paragraph **12.6.2**.

### 9.2. Maintenance / service mode

Maintenance mode is dedicated to do installation of the platform, troubleshooting, to fix problems, to do maintenance and adjustment works.

AB300 platform movement speed is the same as in the normal mode 0,15 m /s. How to activate or deactivate the mode information is available in paragraph **12.6.2. AB300 platform**. See a subsection “**Control from outside**”.

### 9.3. Blocked mode

It is dedicated to block the normal mode of the platform in few cases, when there appear some conditions like ground floor door emergency opening with a special key, safety circuit relay failure or main power failure error detected.

If the platform using is blocked, there needs to call for a technical help in order to find and fix a problem.

After a problem is fixed, in order to reset the mode to normal there needs to restart the power. How to do this see paragraph **8.4. “Restarting the power”**.

### 9.4. Electric emergency lowering (option)

Electric emergency lowering mode is dedicated to drive the platform down until the closest floor landing level in order to release passengers from the platform if there was lost the main power. AB300 platform movement speed in this mode is 0,04 m/s or 2,4 m/min.







How to activate or deactivate the mode the information is available in section **12.6. Platform electric emergency mode (option)**.

### 9.5. Alarm mode

Alarm mode is dedicated to move the platform to an evacuation floor level. In case of alarm the platform moves to the floor automatically itself. Evacuation floor may be any provided floor that should be set on the system. The system has to be connected to the building alarm system. There should be prepared an alarm signal cable to machinery cabinet. Connection of the signal cable to the system should do responsible technician.

## LABELS (ICONS), TEXT WARNINGS

Lifting platform uses the following symbols (icons) and text warnings:

Labels (icons), text warnings	Explanation
	<p><b>Disabled people label</b></p> <p>If the lifting platforms are used in public buildings, each stop-landing must have an international symbol of access. The character height should be at least 50 mm. This symbol indicates that the lifting platform is designed for use by disabled persons.</p>
	<p><b>Fragile ceiling label</b></p> <p>The ceiling should have a warning of the fragile ceiling. The warning must be no less than 300 mm and permanently attached in place immediately visible for any person who attempts to climb on top. This label warns that climbing on the ceiling is prohibited.</p>
	<p><b>Label prohibiting to use the lifting platform in case of fire</b></p> <p>All stop-landings near the lifting platforms must have the securely attached prohibition sign. The character should be at least 50 mm. This label warns that using the lifting platform in the event of fire is prohibited.</p>
	<p><b>Electrical hazard label</b></p> <p>When the electrical work is carried out during the maintenance of the lifting platform, the lifting platform powering disconnection device CB1 must be turned off.</p>
	<p><b>Electrical hazard label</b></p> <p>The lifting platform with the frequency converter – during the work on the electrical system of the lifting platform, turn off the lifting platform power circuit breaker CB1 and wait for at least 10 minutes until the live parts of the lifting platform are discharged.</p>
 <div style="display: inline-block; vertical-align: middle; margin-left: 10px;"> <p>1</p> <p>2</p> </div> 	<p><b>Reduce the spacing of the lower enclosure hole label</b></p> <p>The labels must be attached:</p> <p>(1) the enclosure pit must have the label of reduced spaces of the bottom hole in the enclosure pit. (This label warns of the danger of crushing – the platform mechanical stop must be set to the operating position before entering the enclosure pit.)</p> <p>(2) the machinery cabinet near the emergency devices</p>

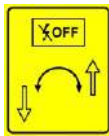

**The label indicating the platform travel direction**

This label is attached in the machinery cabinet near the emergency mode handle.  
This label indicates the travel direction of the platform.

**Label of danger of falling into the platform enclosure and a text warning**

**HAZARD OF FALLING INTO THE LIFTWAY - MOVE THE PLATFORM TO THE LANDING LEVEL - IF THIS IS NOT POSSIBLE, THE RESCUE OPERATION OF PERSONS MUST BE CARRIED OUT ONLY BY A COMPETENT PERSON**

This text warning and the label indicates that the release of passengers (opening the enclosure door of the lifting platform) must be done by lowering the platform to the stop-landing level. If the platform cannot be lowered to the level of the stop-landing, the passenger release operation must be carried out by the competent maintenance person.

**“LOWER THE PLATFORM TO THE STOP-LANDING LEVEL. IF THIS IS NOT POSSIBLE, THE PASSENGER RELEASE OPERATION MUST BE CARRIED OUT BY THE COMPETENT MAINTENANCE PERSON.”**

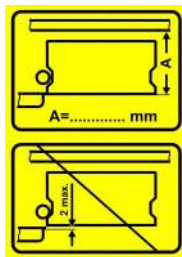

**Label indicating the main nut wear**

This label is mounted on the metal structures of the platform located behind the platform machinery cover.  
It indicates how to control the main nut wear.

**Emergency release instruction**

Passenger release instructions are attached inside of the machine cabinet cover.  
Passenger release instructions contain information indicating how to release the passengers in a safe and proper manner.

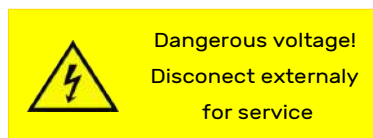

When the main 400V switch is turned off, the control cabinet remains with live wires with a phase, the marking shows where the power (230V) is still present.



## SAFE USE OF THE LIFTING PLATFORM

The lifting platform must be used safely. In order to ensure the safe use conditions, it is necessary to observe the safety precautions.

### 11.1. Safe use of the lifting platform

---



**Attention!**

#### **Risk of injury or damage to the lifting platform!**

- In the moving platform the passenger (s) must hold on to the handrail!
  - Jumping or swinging on the platform is forbidden!
  - During travel, the passenger(s) must not touch the lifting platform enclosure structures!  
In particular, take care that the objects, loose clothing, limbs are not trapped between the platform and the enclosure structures!
  - Baggage must be securely positioned on the platform floor!
  - Do not carry items longer than 2,000 mm in the platform!
  - Do not carry in the platform: explosive, flammable, toxic, oxidizing and other hazardous substances!
  - Transportation of cargo in the lifting platform is prohibited!
  - Do not smoke in the platform!
  - Do not litter in the platform!
  - In the event of a dangerous situation release the lifting platform control button immediately and (or) press the STOP button!
  - Do not use the lifting platform if its condition is not technically sound!
  - It is essential that the lifting platform passenger immediately informs the maintenance service and (or) the owner of any malfunctions and operational failures of the lifting platform!
- 

### 11.2. Platform operation in the event of fire

---



**Attention!**

#### **Fire and smoke danger to life!**

- In case of fire, the use of the lifting platform is prohibited!
- 

### 11.3. Stop-landing door opening area

---



**Attention!**

#### **The passenger may be affected by the stop-landing door!**

- Do not stand in the working area of the stop-landing door!
  - Do not allow children to play within range of the stop-landing door!  
**NOTE:** The stop-landing door closing force is reduced and passengers cannot cause additional risk, but they should always free the working area of the stop-landing door.
-

#### 11.4. Stop-landing threshold and platform

---



**Attention!**

##### **Tripping hazard!**

- In order to avoid tripping hazards before climbing of or on the platform, pay attention to the vertical distance between the platform and the stop-landing doorstep.
- 

#### 11.5. Help for Passengers

---



**Attention!**

##### **Ergonomic hazard!**

- Persons who for some reason cannot use the lifting platform controls and (or) to get on the platform independently, can use the lifting platform only with the accompanying person.
- 

#### 11.6. Lifting platform maintenance

---



**Attention!**

##### **Risk of loss of life or damage to the lifting platform!**

- The maintenance of the lifting platform must be carried out by the competent maintenance personnel (see “Vertical lifting platform maintenance manual”)!
- 

#### 11.7. Passenger release operation

---



**Danger!**

##### **Danger of falling into the enclosure pit of the lifting platform!**

- Passenger release operation must be carried out only by a competent maintenance worker or a person authorized by the lifting platform owner to monitor trapped passengers (see the section “Passenger release”)!
-

## EMERGENCY MANUAL OPERATION

Prior starting release the passengers, carefully read an information presented below!

---

### Danger of falling into a lift well!

---



**Attention!**

- Passenger release operation must be carried out according to the „EMERGENCY MANUAL OPERATION INSTRUCTION“ contained in the „USER AND MAINTENANACE MANUAL“ and on the back side of the elevator electrical compartment panel!
- The passengers release operation can only be carried out by a:
  - competent maintenance personnel;
  - personnel authorized by the lifting platform owner to rescue trapped passengers.
- The lift owner must ensure that the authorized person is trained to carry out maintenance work and passenger release operations.
- A person authorized by the lift owner to rescue trapped passengers, can open a landing door in the emergency mode only when the platform is at the landing!
- If a person authorized by the owner, using hand-held, and (or) emergency electrical devices, is unable to lower the platform to the stop-landing, the passenger release operation must be performed by the competent maintenance worker!
- When it is not possible to lower the platform to the landing, the qualified maintenance personnel must take all necessary precautions in order to avoid falling into the lift well!
- The lifting platform owner must take care that the maintenance service, taking part in the rescue of persons, under any circumstances can safely access of the building and have the access to the lifting platform.

---

### 12.1. Communicating with passengers

Notify the passengers on the platform that the release operation is in progress.

Determine whether the passengers need medical assistance, and if so, call the medical assistance.

Communicating with the stuck passengers try to find out the cause of a jam.

If the platform had stopped between the landings, inform the passengers that the platform will be lowered/raised to the landing during the release operation.

Make sure the passenger limbs, objects, or other baggage are not trapped between the lifting platform enclosure and the platform.

Ask the passengers to hold on the handhold during platform movement, and not to touch the lifting platform enclosure.

### 12.2. Checking safety circuit

Make sure the emergency stop button is disengaged.

Check that all the landing doors are closed and locked.

Check the safety circuit indication: if the safety circuit indicator shows a safety circuit tripping, but this did not happen due to passengers drawing-in or trapping, the safety circuit is to be bypassed by inserting a bridge into the contact. Enter the emergency lowering mode.

### 12.3. Emergency mode activation

To activate the emergency mode: press and hold for 2 secs. the button „SERV“ on the Base unit board.

Platform movement directions can be activated by pressing on buttons „UP“ and „DOWN“.

If to hold the button „DOWN“, the platform will be driven to the lowest floor. Platform will stop automatically at the landing level.

To open the door lock, push the call button on the door.

Activate „Auto“ platform operation mode. Push and hold the button „AUTO“ for 2 sec.

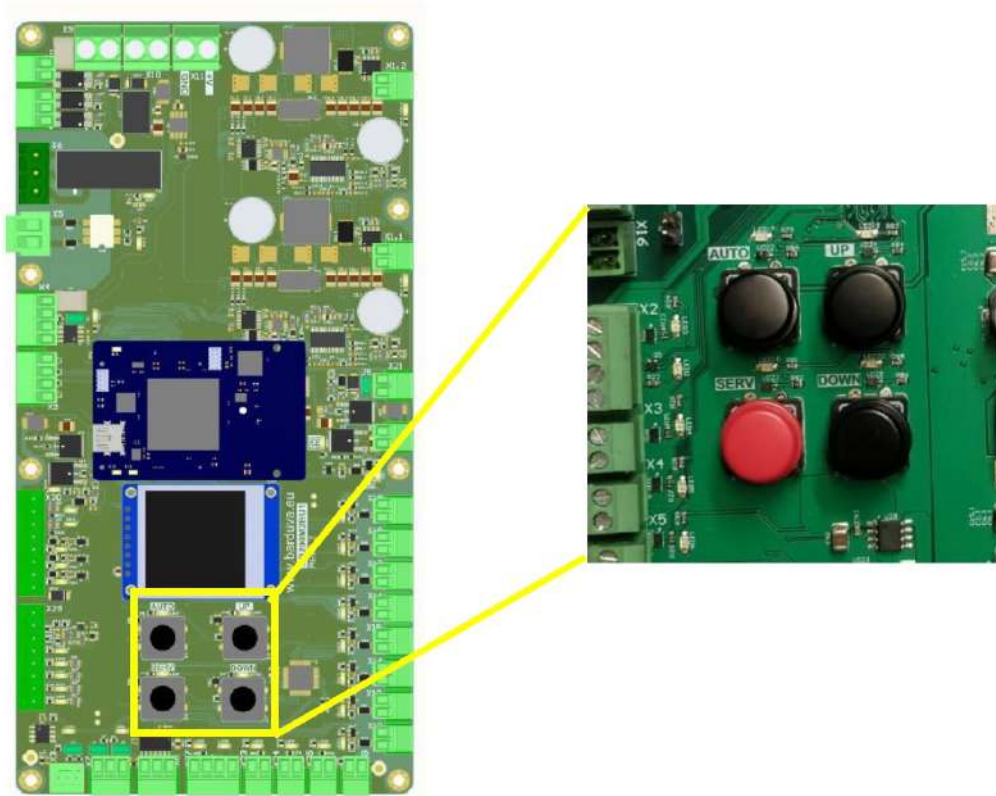

#### **12.4. Landing door opening**

When the platform is at the landing level, unlock and open the landing door with the use of special triangular key.

Help passengers to leave the platform.

Close the stop-landing door. Make sure that the stop-landing door is properly closed and locked.

Perform the lifting platform maintenance (troubleshooting).



**Notes.** If the door was opened with emergency key, a system reset is required.

#### **5. Further use of lifting platform**

If the passenger release operation was carried out by the person authorized by the owner, he must immediately notify the maintenance service!

Further use of the elevator is allowed only after the inspection and permission of the supervising maintenance company.

# LIFTING PLATFORM MAINTENANCE

Safety and longevity of use of the lifting platform depends on the timely and periodical maintenance of the lifting platform.

## 13.1. Maintenance information

The maintenance must be carried out in accordance with this manual and the Maintenance manual of the vertical lifting platform.

The maintenance must be carried out by competent maintenance personnel equipped with necessary tools and devices.

It is necessary to take care of the competence of the maintenance service personnel.

Maintenance of the lifting platform must be carried out in accordance with the frequency specified in the Maintenance manual of the vertical lifting platform.

If failures that may cause an accident, or failures endangering human health, life, property or the environment are found during the maintenance, and it is not possible to repair them, the operation of the lifting platform must be stopped immediately. The maintenance service must inform the owner of the lift.

It is necessary to organize the delivery of spare parts for repair. Only original parts must be used for repairs of the lifting platform.

## 13.2. Maintenance documentation

The lifting platform maintenance must be performed in accordance with the Vertical lifting platform maintenance manual, and the national legislation of the country in which the lifting platform is operated.

Information relating to the actions performed during the lifting platform maintenance (inspection of technical condition, repairs and other), and modifications must be written in the lifting platform maintenance logbook. The lifting platform logbook form is given in Annex B of this manual.

## 13.3. General safety requirements



**Danger!**

### **Risk of loss of life or damage to the lifting platform!**

- The lifting platform maintenance must be performed by a competent person!  
Before starting the lifting platform maintenance, the competent person must make familiar and analyse the technical documentation of the lifting platform!



**Danger!**

### **Crushing danger for life when the maintenance work is carried out under the platform!**

- Before entering under the platform, the following requirements must be met:
    - mechanical stop must be in the operating position!
    - emergency stop device in the enclosure pit of the lifting platform must be activated!
-



**Danger!**

**Fall risk to life due to maintenance work being carried out at a height!**

- During the maintenance operations, for instance, cleaning the exterior of the lifting platform enclosure, all requirements for the work at height must be complied with !
  - Any work at a height must be carried out from mobile work platforms, specially designed stationary platforms or other equipment ensuring adequate safety!
- 



**Danger!**

**Risk of serious injury due to moving parts of the lifting platform!**

- Do not touch any moving parts during the maintenance: drive elements, suspension system components, etc.!
- 



**Danger!**

**Risk of injury to persons or damage to objects!**

- Make sure there are no foreign persons or objects in the vicinity during the lifting platform maintenance !
- 



**Danger!**

**Electrical shock hazard to life!**

- Prior to the lifting platform maintenance, the main switch must be set to "O" and locked in that position to prevent inadvertent activation of the switch!  
This switch turns off all electrical devices of the lifting platform, except for the box-outlet power.
- 



**Danger!**

**Ergonomic hazard!**

- During the lifting platform maintenance, the floor of the working area and machinery installation must be illuminated by at least 200 lux light intensity!
- 

**The risk of serious injury due to the lack of personal protective equipment!**

- Personal protective equipment is essential and mandatory during the maintenance!



#### 13.4. Safety during maintenance work under the platform

---



**Danger!**

**Crushing danger for life when the maintenance work is carried out under the platform!**

- Before entering under the platform, the mechanical stop must be in the operating position!
- 

**For safe maintenance operations of the lifting platform carried out under the platform, it is necessary to perform the following steps:**

- 1 Make sure that the platform is at least 2 meters from the enclosure pit.
- 2 Use the special key to unlock and open the machinery cabinet, located near the bottom stop-landing door.
- 3 Set the main switch CB1 to position "O".
- 4 Use the mechanical platform stop handle to set the mechanical stop of the platform to the operating position. **NOTE:** If the mechanical stop of the platform is set to operating position, normal use of the platform becomes not possible.
- 5 Press the platform control device in the stop-landing – the platform must not move.
- 6 Close and lock the machinery cabinet. Make sure that the machinery cabinet door is properly closed and locked.
- 7 Use a special triangular key to unlock and open the door to the enclosure pit of the lifting platform.
- 8 Use the tool to press the safety device axis of the electrical door close control so that the door lock slides out to the end. This operation must be carried out to prevent inadvertent automatic closing and locking of the stop-landing door.
- 9 Once inside the enclosure pit, press and activate the emergency braking device in the platform enclosure pit.

Upon completion of the maintenance work under the platform, it is necessary to perform the following steps:

- 1 Turn clockwise the emergency braking device in the enclosure pit for release.
- 2 Close and lock the landing door.
- 3 Use the special key to unlock and open the machinery cabinet door.
- 4 Use the mechanical platform stop handle to set the platform mechanical stop to "Off" position.
- 5 Close and lock the machinery cabinet door. Make sure that the machinery cabinet door is properly closed and locked.

### 13.5. Platform cleaning

---



**Warning!**

#### **Risk of loss of life or damage to the lifting platform!**

- During cleaning take appropriate measures to ensure that water does not enter the enclosure pit of the lifting platform, the machinery cabinet, the platform control panel and other electrical equipment!
  - Never use high-pressure jets for cleaning, etc.
  - Electrical equipment should be cleaned using dry cleaning tools, and compressed air (for example, dry duster)!
  - After cleaning, the lifting platform must be completely dried before using!
- 



**Warning!**

#### **Damage to the lifting platform!**

- Do not use rough and aggressive cleaning agents for surface cleaning !
  - Cleaning means must be suitable for washable surfaces! In absence of special cleaning means, use a soft cloth or sponge soaked in soap and water solution !
- 



**Warning!**

#### **Risk of loss of life or damage to the lifting platform!**

- Clean external enclosure of the lifting platform from stationary trolleys or mobile elevating platforms for lifting people!
- 



**Warning!**

#### **Risk of loss of life or damage to the lifting platform!**

- Cleaning of internal areas of the lifting platform must be carried out by the competent maintenance personnel!
  - Prior to the lifting platform cleaning, turn off the lifting platform power-off device!
  - Do not install the ladder on the inner surfaces of the platform for cleaning the parts!
-

### 13.8. Scope of maintenance operations

The table indicates the tests of the lifting platform design and its equipment mandatory during their maintenance, the inspection methods and frequency of testing.

The detailed scope and frequency of maintenance is specified in the Maintenance manual of the vertical lifting platform.

Test code	Lifting platform design and its equipment	Maintenance scope			Additional information
		Testing method	Lubrication	Cleaning	
1	Lifting platform technical documentation	VI	-	-	
2	Free space in front of the machinery cabinet and the landing doors	VI, M	-	-	
3	Enclosure of the lift	VI	-	C	
4	Lift machinery cabinet	VI, FT	-	C	
5	Landing doors	VI, FT, M	-	C	
6	Platform emergency mode system	VI, FT	L	-	
7	Platform	VI, FT, M	-	C	
8	Lifting platform controls	VI, FT	-	C	
9	Lifting platform indicators	VI, FT	-	C	
10	Suspension system and drive belts	VI, FT, M	L	C	
11	Platform drive system	VI, FT, M	-	C	
12	Platform deflection system	VI, FT	L	C	
13	Mechanical and electrical safety devices of the lifting platform *	VI, FT	-	C	

\* Checking the over speed device requires activation of the over speed governor cable tension solenoid. The solenoid is activated by a button from the electrical compartment. Actuation of the solenoid interrupts the safety circuit, after which the system must be reset.

VI – visual inspection is used to check the component parts visually.

FT – functional testing is used to verify whether the current measures and means carry out their function in accordance with the requirements.

M – the measurement is used to check the compliance of devices to the established values.

L – lubrication.

C – cleaning.

## SPECIAL TOOLS

The following special tools are provided with the lifting platform:

- special key to unlock/lock the machinery cabinet door;
- special triangular key to unlock the stop-landing door;
- panel removal tool;



Keys to unlock/lock platform control panel and machinery room

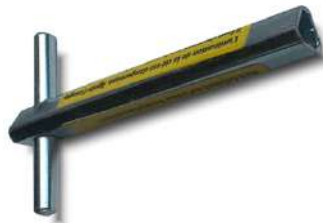

Emergency key to open/close the platform shaft door (“delta” triangle)



Panel's shield KEY

# SAMPLE EC DECLARATION OF CONFORMITY

“Barduva” JSC  
Beržuonos str. 2, LT-02121, Vilnius, Lithuania  
Phone +370 5 231 0770  
Phone +370 5 231 0071  
Fax +370 5 231 0773  
E-mail sales@barduva.eu  
www.barduva.eu



---

## EC DECLARATION OF CONFORMITY

---

**Business name and full address of the manufacturer**

“Barduva” JSC  
Beržuonos str. 2, LT-02121, Vilnius, Lithuania

**Name and address of the person authorised to compile the technical file**

**Installation address**

**Type of the machinery**

**AB300**

**Description of the machinery**

Vertical lifting platform affixed to a building structure intended for use by persons with impaired mobility

**Serial number**

**Year of construction**

**We hereby declare that the machinery fulfils all the relevant provisions of the following European Directives and Harmonised Standard that confirms LIFTINSTITUUT EC-type examination certificate NL18-400-1001-205-01**

**Name of Notified body**

**LIFTINSTITUUT**

**Address of Notified body**

Buikslotermeerplein 381  
1025XE Amsterdam Netherlands

**Accreditation Number**

**CE 0400**

**European Directives**

2006/42/EC

**Harmonised Standard**

EN 81-41:2010

EN 81-20:2020

EN 81-58:2018

**Place of the declaration**

“Barduva” JSC  
Beržuonos str. 2, LT-02121, Vilnius, Lithuania

**Name of the person to draw up the declaration**

**Signature**

**Date of the declaration**

**VERTICAL LIFTING PLATFORM MAINTENANCE LOGBOOK  
VERTICAL LIFTING PLATFORM AB300**

**Original manual EN**

## **MAINTENANCE LOGBOOK FORM**

This document contains information about the manufacturer, owner, installer, maintenance service of the lifting platform, technical characteristics, maintenance results and modifications of lifting platform.

This document is an integral part of the Maintenance manual of the vertical lifting platform and the Installation manual of the vertical lifting platform!

Fill in all the boxes of this document after installation of the lifting platform and before it's use!

Prior to the lifting platform maintenance, carefully read this passenger and the Maintenance manual of the vertical lifting platform!

After replacement and (or) modification of the lifting platform parts, record the details of the replacement parts in this document, and attach the documents of these parts: declarations/certificates, assembly, access information etc.

## 1. General data

<b>Manufacturer</b>	Name	Barduva UAB
	Address	Beržuonos str. 2, LT-02121, Vilnius, Lithuania
	Tel.:	Fax:
	E-mail	

<b>Description of the lifting platform</b>	<b>Vertical lifting platform for people with reduced mobility</b>
--	---

<b>Data</b>	Type	AB300
	Serial number	
	Year of manufacture	

**Address of installation**

**Installation date**

<b>Fitter</b>	description	
	Address	
	Tel.	Fax
	E-mail	

**Lifting platform commissioning date**

## 2. General technical specification

<b>General</b>	Rated load
	Number of persons
	Rated speed
	Lifting height
	Number of stop-landings

<b>Platform</b>	Platform width
	Platform length
	Platform height

<b>Drive</b>	Drive type
	Rated power

<b>Controls</b>	Controls in stop-landings	Non-forced operation type
	Platform control devices	Emergency operation type

<b>Doors</b>	Door type
	Door drive type
	Number of doors
	Door height
	Door width

<b>Guardrail</b>	Enclosure design	<input type="checkbox"/> Glass panels <input type="checkbox"/>
	Free height on top of the enclosure	
	Free height in the bottom of the enclosure	

<b>Electrical equipment</b>	Voltage
	Frequency
	Main fuses
	Safety circuit voltage

### 3. Lifting platform owner

---

<b>Owner</b>	Name		
	Address		
	Tel.:		Fax:
	E-mail		
	Date of use	as of	Till

---

---

<b>Owner</b>	Name		
	Address		
	Tel.:		Tel.:
	E-mail		
	Date of use	as of	Date of use

---

---

<b>Owner</b>	Name		
	Address		
	Tel.:		Tel.:
	E-mail		
	Date of use	as of	Date of use

---

---

<b>Owner</b>	Name		
	Address		
	Tel.:		Tel.:
	E-mail		
	Date of use	as of	Date of use

---

---

<b>Owner</b>	Name		
	Address		
	Tel.:		Tel.:
	E-mail		
	Date of use	as of	Date of use

---

---

<b>Owner</b>	Name		
	Address		
	Tel.:		Tel.:
	E-mail		
	Date of use	as of	Date of use

---

#### 4. Maintenance person

---

<b>Maintenance service</b>	Name		
	Address		
	Tel.		Fax:
	E-mail		
	Maintenance date	as of	Till

---

---

<b>Maintenance service</b>	Name		
	Address		
	Tel.		Fax
	E-mail		
	Maintenance date	as of	Till

---

---

<b>Maintenance service</b>	Name		
	Address		
	Tel.		Fax
	E-mail		
	Maintenance date	as of	Till

---

---

<b>Maintenance service</b>	Name		
	Address		
	Tel.		Fax
	E-mail		
	Maintenance date	as of	Till

---

---

<b>Maintenance service</b>	Name		
	Address		
	Tel.		Fax
	E-mail		
	Maintenance date	as of	Till

---

---

