



OTHER OPTIONS:

GATE

Automatic upper gate
Automatic lower gate

CONTROL

Configurable control side
Dual control on the platform
Auto dialer on the platform
Braille on the control

SAFETY

Battery emergency lowering device
Bellows
Infra-red barrier

FINISH

Painted in any RAL color
Brushed Stainless Steel

User group	Ambulant and wheelchair users
Suitability	For internal or external use
Travel	From 600 mm up to 3000 mm
Number of stops	2
Maximum capacity	400 kg
Drive type	Belt
Power	220-240 V, 1 phase, 16A 380-400 V, 3 phase, 10A, 50 Hz
Lighting	Controls illuminated
Safety edge	Safety edge-under platform proximity sensors
Handrail	Integrated to lift cabin (on both sides)
Machine room	Integral to guide rails
Floor	Anti slip rubber (Anti slip diamond plate for outdoor version)
Finish	RAL 9006 (Anodized aluminum)

PROTECTION COVER



Protection cover for the RB150 platform.

In the case of infrequent use of the platform (vacations, prolonged absence), this tarpaulin avoids the accumulation of leaves, dust, detritus, snow. It will protect from a part of the rain and therefore ensure greater sealing or risks of appearance of oxidation points.

Easy to install and to detach.
Provides with its ultra practical storage pouch.

Technical specifications

Polyester. Size 1100 x 1400 mm.
On a 1100 mm platform height.
Compatible with smaller formats.

Barduva, JSC
Beržuonos str. 2, LT-02121 Vilnius, Lithuania
00 370 5 231 0770 (Phone)
sales@barduva.eu
www.barduva.eu

barduva

RB150

Open Platform Lift

**UNLOCK YOUR SPACE
WITH A 90-DEGREE EXIT**

MADE IN EU

RB150

Open Platform Lift



Barduva RB150 is an Open Platform Lift, also known as Wheelchair Lift, which provides internal or external vertical travel up to 3 meters. Our Open Platform Lift can accommodate changes in level from 600 mm up to 3000 mm in commercial and domestic environments and is appropriate alternative solution to a fully enclosed platform lift.

RB150 is specifically designed for applications with little or no alterations to existing buildings. The open type design offers an aesthetically pleasing solution

with brushed stainless steel finish as option. The lift provides a safe and easy way to gain access to a property where stairs would otherwise prevent wheelchair access.

It is designed to give customers choice and flexibility.

RB150 Wheelchair Lift is a space saving and cost effective way to provide access for everyone to your home or workplace.

All our lifts are supplied with a 24-month warranty, as standard, and we offer a range of maintenance and service options, which can be tailored to suit your specific requirements.

FEATURES

- Modern lightweight design
- Stainless steel construction as option
- Low space requirements
- High level of security
- Silent operation
- Simple to use
- No pit required
- Simple to install and easy to service
- Overall low maintenance and running costs

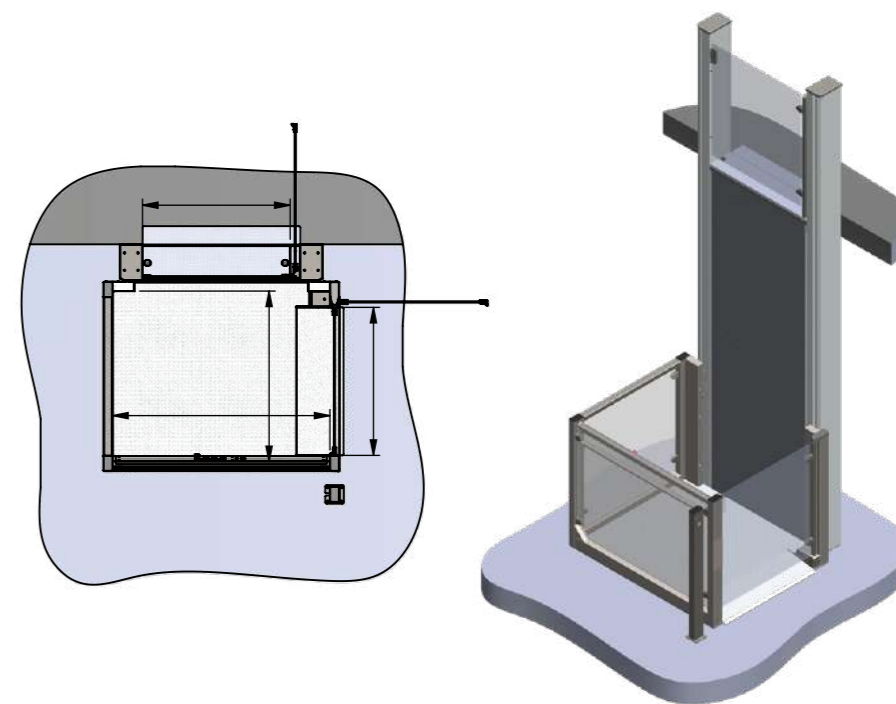

DISSEMBLE PLATFORM (OPTIONAL)

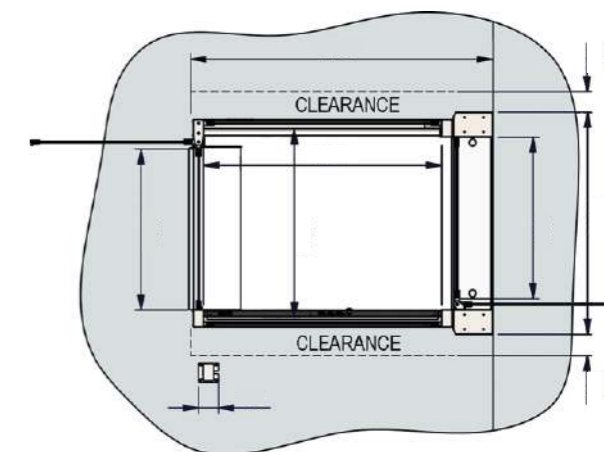
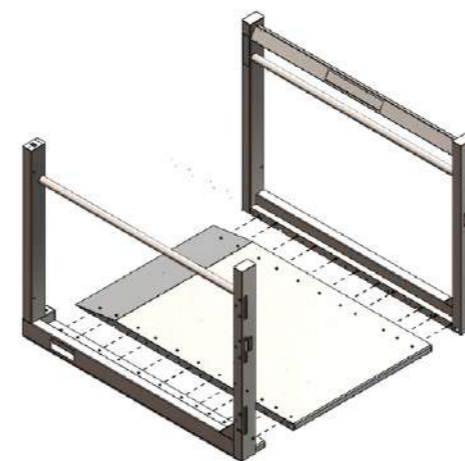

BELLOWS UNDER THE PLATFORM

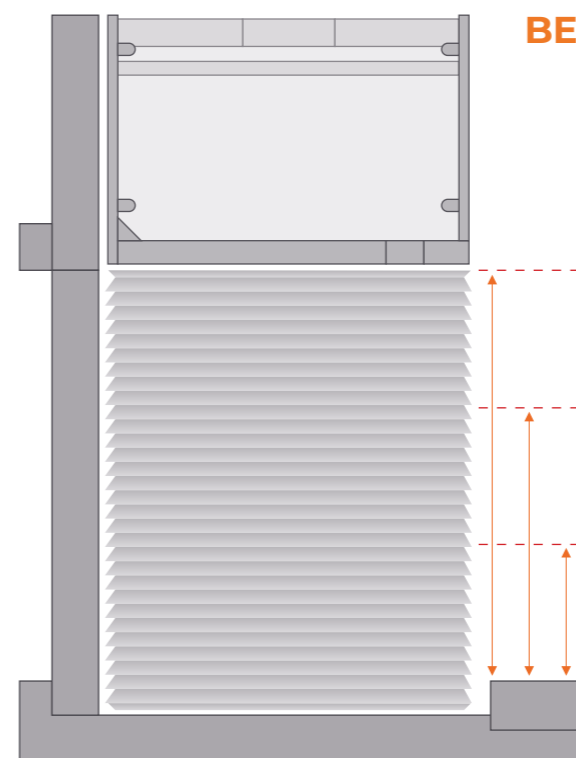

3 lifting heights:

from 2010 to 3000 mm,
pit = 350 mm.

from 1010 to 2000 mm,
pit = 260 mm.

from 600 to 1000 mm,
pit = 170 mm.

Fixations: on ground floor, at the four corners of the below, and at the platform, fixations will be provide.

Platform size possible:
1100 x 1400 mm
(shaft 1300 x 1760 mm).
Gate opening = 950 mm.

