

VERTICAL PLATFORM LIFT

RB150

RB150 Assembly and maintenance MANUAL

(Translation from the Original Lithuanian manual)

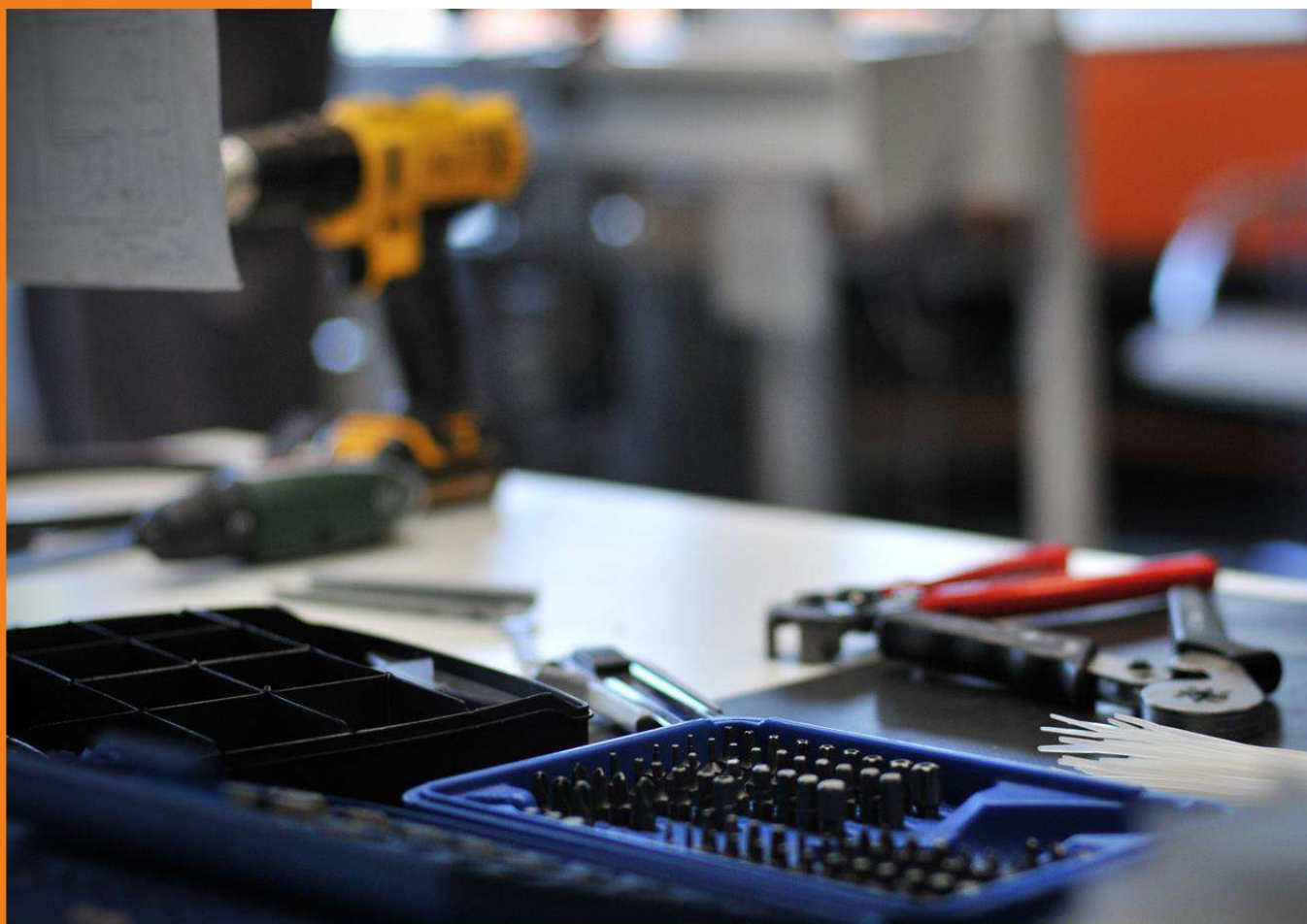

Revision No.

4.0/17-07

Manual code 150-1-EN-2

Date 2017 07 10

BARDUVA

Liepkalnio str. 61, LT-02120, Vilnius, Lithuania

Tel.: +370 5 2310770

Fax: +370 5 2310773

Email: sales@barduva.eu

www.barduva.eu



CONTENT

1. SAFETY	4
1.1 Possible hazard situations	4
1.2 Electrical hazard	4
1.3 Personal safety equipment	4
2. STORAGE	5
3. PREPARATORY WORK AND MATERIAL	6
3.1 Device installation	6
3.2 Tools for installation	6
4. ASSEMBLY INSTRUCTIONS	7
4.1 Mounting lift's columns	7
4.2 Platform connection	10
4.3 Wires connection	11
4.4 Call button column connection to the mainboard	12
4.5 Testing platform and closing electrical compartment lids	13
4.6 Finishing assembly of the platform lift	15
4.7 Assembled platform lift RB150	17
5. ADDITIONAL MAINTENANCE OF THE PLATFORM LIFT RB150	19
5.1. Gates spiral tensioning	19
5.2. Belt gear tensioning/platform horizontal adjustment	21
5.3. Automatic gates programming and maintenance (optional)	22
5.3.1. Self learning of „Ceitamatic“ door opener	22
5.3.2. MASTER and SLAVE mode	22
5.4. Platform lift diagnostic via USB cable	24
5.4.1. Adjust locks and doors	29
5.5. Adjusting door closing sensors	30
6. RB150 CHECK LIST	31
7. INFORMATION ABOUT INSTALLER	33
8. IMPORTANT NOTES FOR INSTALLERS (TWO VERSIONS)	34
9. ELECTRICAL SCHEMES	36

1. SAFETY

Prior starting the assembly of the platform lift and during installation, it must be taken all necessary actions to avoid dangerous and hazardous situations to the persons or the environment.

The platform lift installation must perform skilled personnel. This personnel have to be informed of the instructions given in this manual and also have to be familiar with national statutory regulations for safety and general prevention of accidents at each country by domestic laws.

1.1. Possible hazard situations

- Work at height: corresponding safety measures have to be taken to guarantee the safe work at height. Depending on the domestic laws use appropriate hoisting equipment, etc. ladders, scaffolds, scissor lift or other;
- Heavy parts: some of the platform lift parts are heavy, so it is important to lift it up by two persons or in some cases use hoisting equipment;
- Danger zones: secure the assembly area and area near it with signs and / or other warning signs, restriction materials;
- Falling things: never work under the platform, if there is a person already working on it. Before entering the shaft make sure that shaft components are fixed properly;





1.2. Electrical hazards

Symbol	Hazardous situation
	The electrical shock possibility in the machine room and / or near the lift parts having electrical components!

All the electrical instalation work have to be carried out by skilled personnel, as stated in the domestic laws in each country in order to avoid the accidents.

Machine room cover have to be closed and locked all the time, when the work in the machine room is finished and / or technicians are not near the machine room.

1.3. Personal safety equipment

		Personal safety equipment: safety shoes, gloves, helmet, safety glasses, and earplugs, clothes.
		

It is very important to use personal safety equipment during the instalation and also using the instalation tools and machines to avoid or at least reduce personal injuries.

2. STORAGE

Storage of the material should not take place in high humidity environments. Doors should be stored within temperature -25 to 55° C. The storage area should be dry and free of dust. The periodical checks of the packed components, for possible existence of condensed water or damaged packaking can help to protect the material.

3. PREPARATORY WORK AND MATERIAL

Before mounting the platform please check the mounting place for quality.

Measure height and width of lifting platform mounting place and check if the level of walls does not have inclination into the shaft. Also measure the horizontality of mounting ground and dimensions of pit (if intended) for lifting platform lower case.

3.1. Device installation



Device	Remarks
Automatic or self-raiser for moving the lift platform.	
Weights (475 kg) for testing static and dynamic load of platform.	

3.2. Tools for installation

Tool name	Remarks
Perforator	
Electrical drill	
Drill kit for metal construction	
Drill kit for concrete construction	
Level	
Electrical cable extender	
Multimeter	
Accumulator drill with adjustable tightening torque	
Head kit for electrical drill	
Electrical disc saw with disc kit	
Laser distance meter (15 m)	
Plumb-line (plumb-line length depends on lift height shaft)	
Nylon rope	
Knife	
Hammer	
Pencil	
Tape-measure 5 m	
Screwdriver kit	
Adjustable torque wrench (20 Nm to 200 Nm) Head kit for torque wrench.	
Device for rivet	
Wrench kit	
Flat file	
Oval file	
Two pieces of clamps	

4. ASSEMBLY INSTRUCTIONS

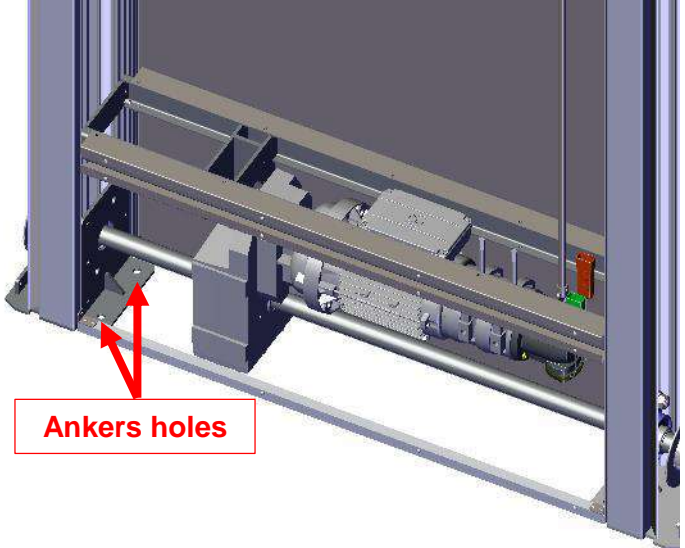
4.1. Mount lift's columns

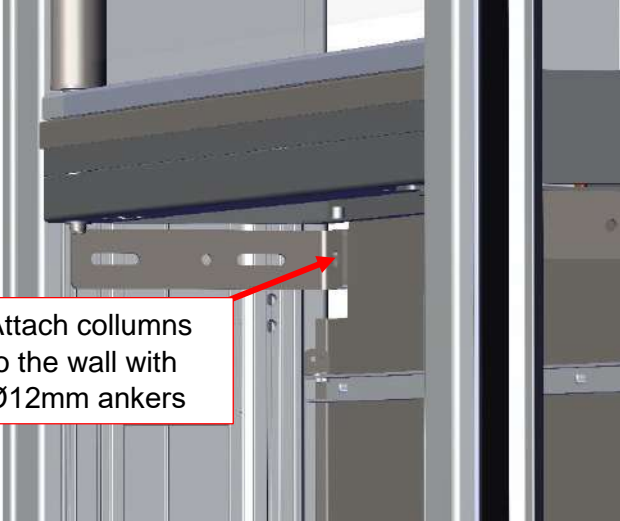
Description	Figure
<p>First, you must to fasten lift's columns to the floor and to the wall. In package, you will find Ø12 diameter anchors. Fasten columns as shown in the picture.</p> <p>You need to fasten 4 (four) ankers. Make sure, that columns stands correct.</p>	 
<p>Before attaching platform to the columns, you must attach columns to the wall with brackets.</p>	 <p>Attach collumns to the wall with Ø12mm ankers</p>

Ankers must be fitted in both sides of the columns as shown in picture.

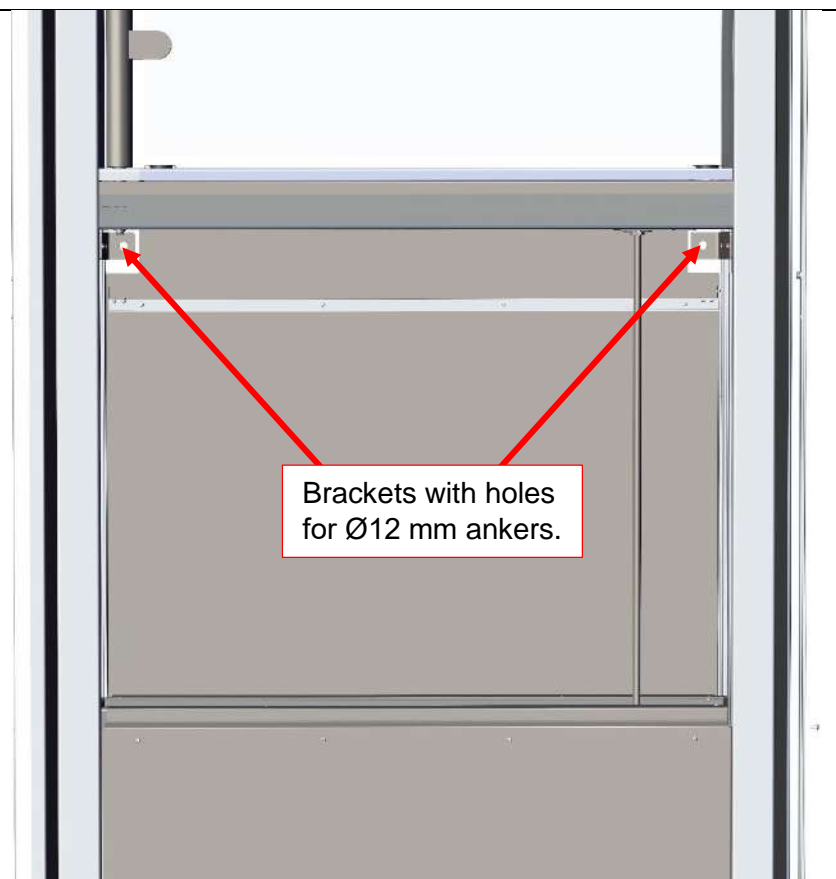

When finished attaching columns to the wall, close the back lid as shown in the picture.

First, slide in the upper side under the cover plate on the rails, then pull all pallets to the bottom until they fix in the place with other pallets.

NOTE: Make sure the lid's upper side is on top (marked with dashes in the picture).

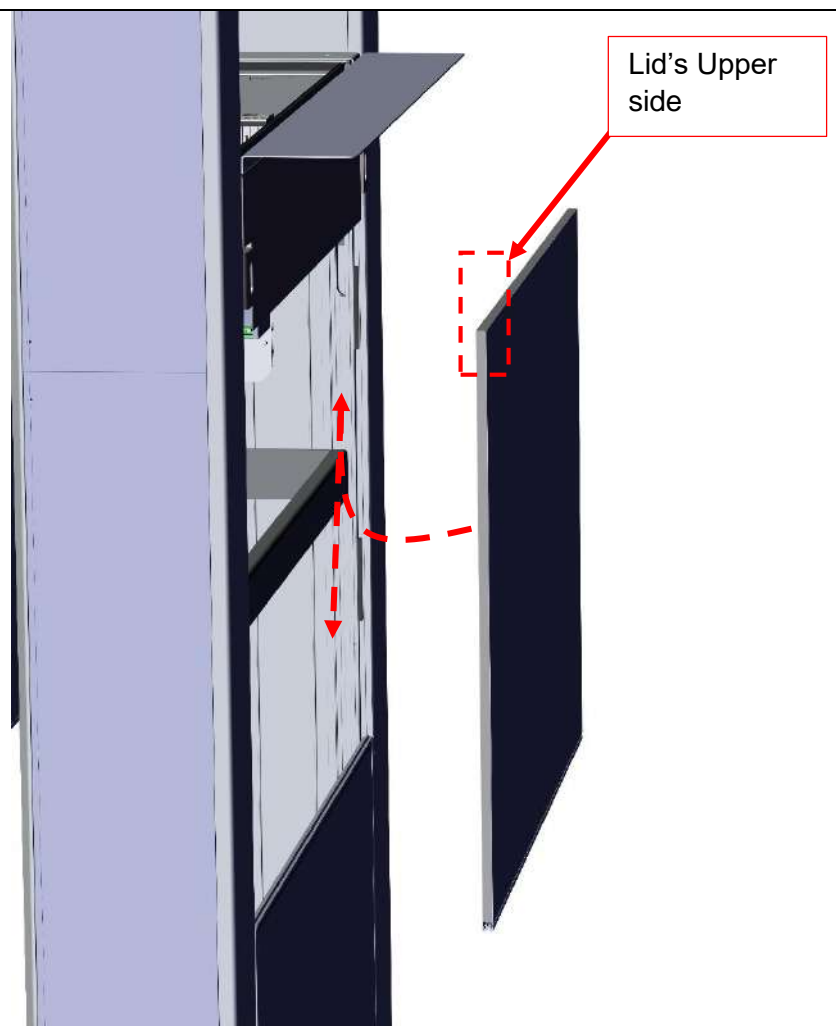

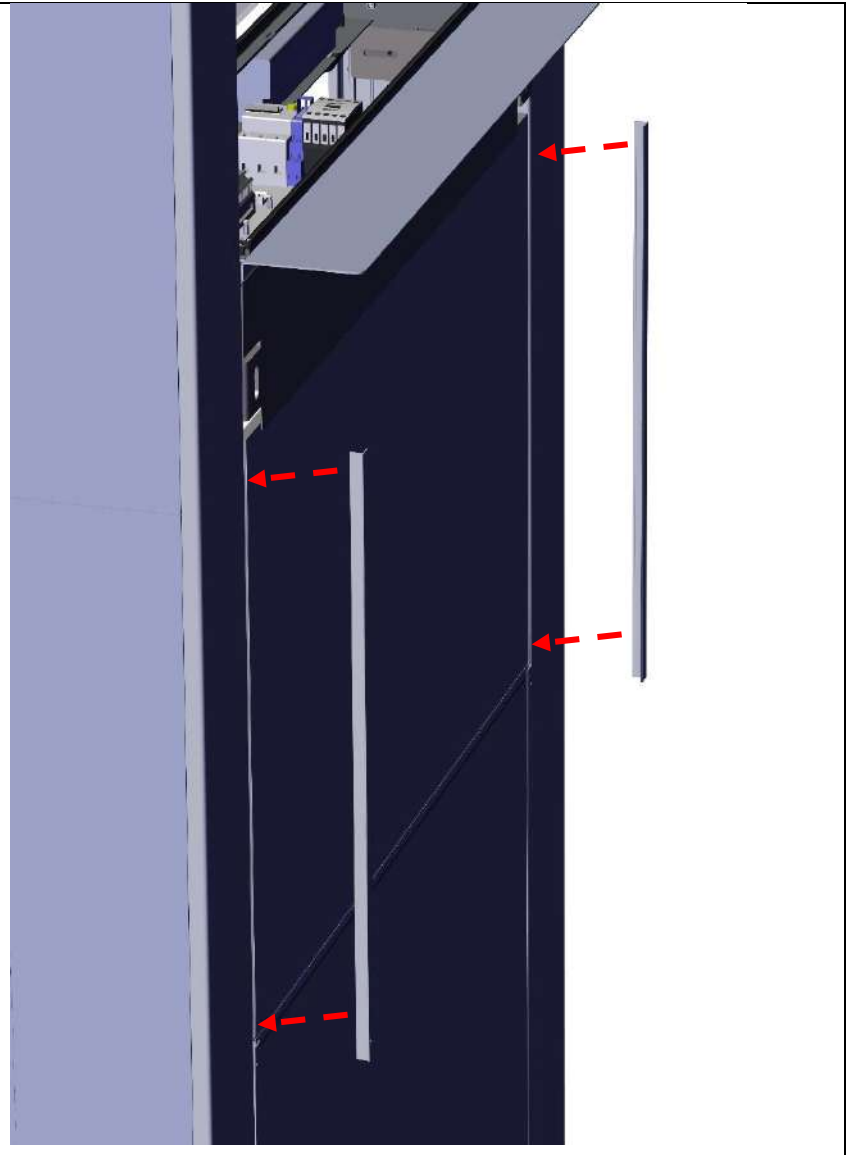

Fix the palletes with fixing profiles. Slide in the profiles in the fixing holes and start pushing them until “click” sound. Do the same to all fixing profiles.

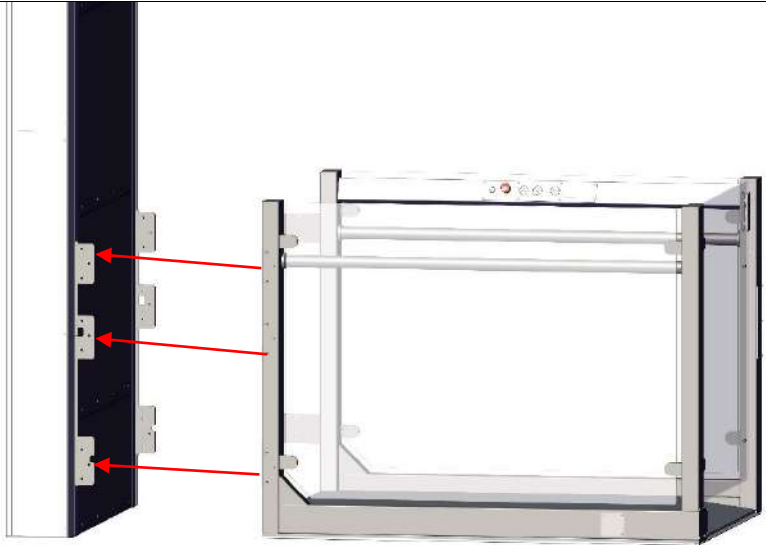
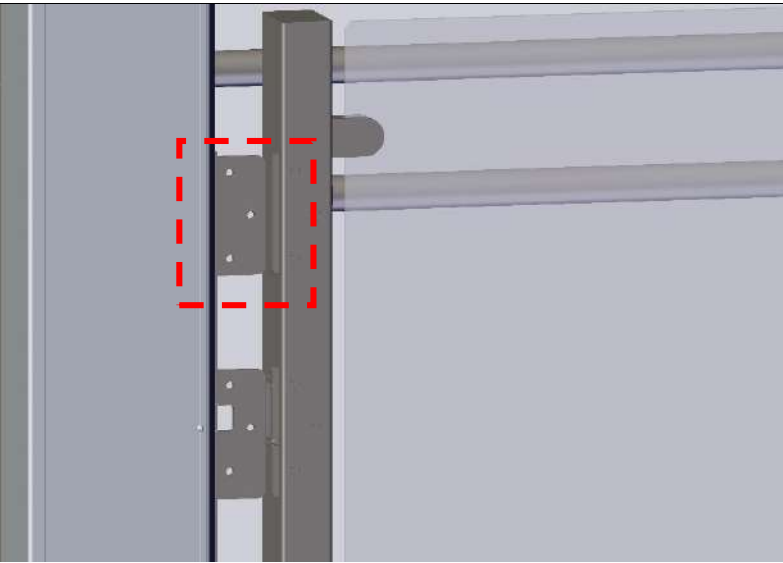
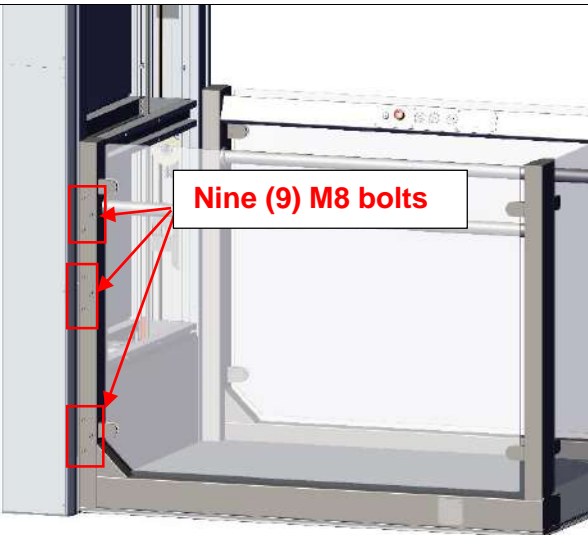

4.2. Platform connection

Description	Figure
<p>When finished mounting lift's columns, put a platform near columns as shown in the picture. This must be done, because you have to connect all platform's electricity to the main board. Make sure, you have enough space between platform and columns, to close main electricity cover.</p> <p>NOTE: Do not move away palette, this is easier to mount rollers after all wires connection.</p>	
<p>Three brackets in both sides of the platform, must be fitted in to the bracket holders on the platform. Each bracket attached by 3 M8 bolts.</p> <p>NOTE: before attaching bolts, don't forget to connect plug and play cables (displayed on 4.3): They are marked with numbers "1, 2 and 3". Just connect them and hide in to the hole on the platform.</p>	
<p>Attach 9 (nine) M8 bolts to the holes in left side, and do the same thing to the right side.</p> <p>Close the holes with covers and you are ready to start the lift for testing.</p>	

4.3. Wires connection

Description	Figure
<p>Do not connect platform to the columns yet. First, you must connect cables between platform and columns.</p>	
<p>Just screw all connectors as shown in the picture. All cans are different, so you won't be able to mix them by mistake. Also all cans are marked with numbers in case of mistakes.</p>	

4.4. Call button column connection to the mainboard

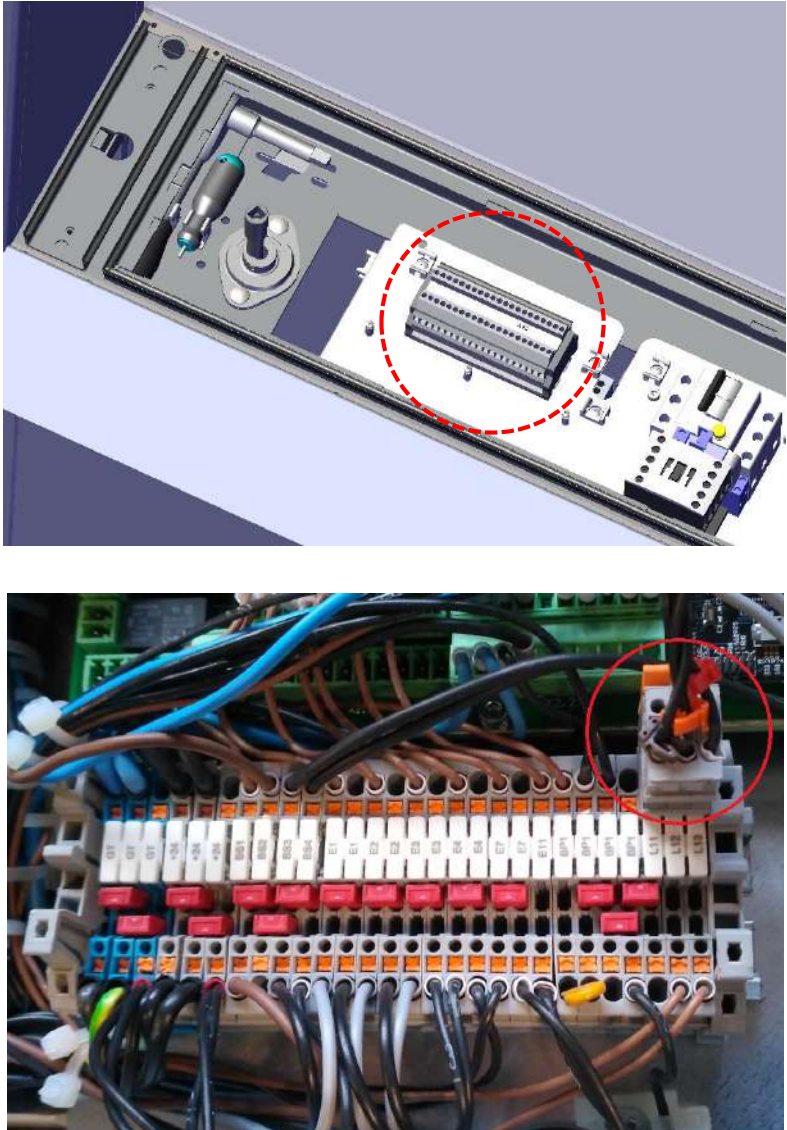
Description	Figure
<p>In the package you received a call button with column. You have to pass cables trough your desired place or tubes. When cable passed, connect it to this board.</p> <p><u>NOTE: See paragraph 4.7.</u></p>	
<p>Connect call button column wire to the to the wire distribution terminal as it shown on the picture.</p> <p>The wire must be connected using the connector that is already attached to the wire.</p>	

4.5. Testing platform and closing electrical compartment lids

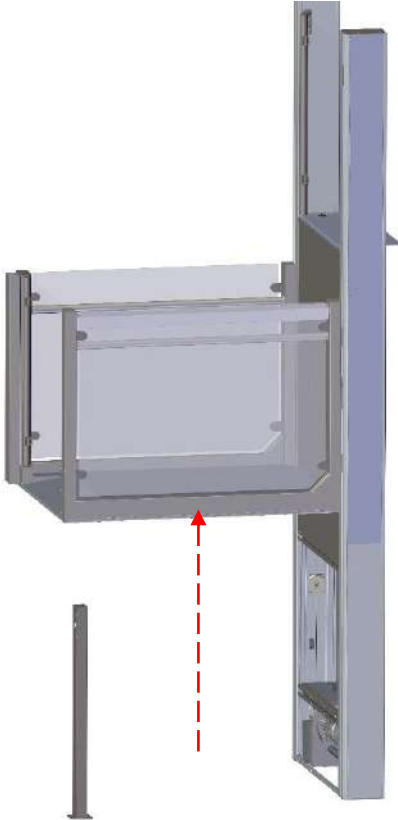
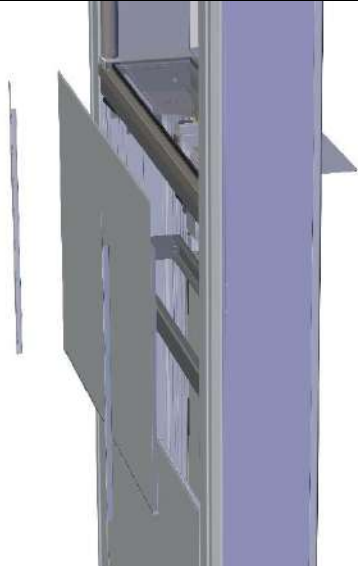
Description	Figure
<p>After finishing mounting platform, columns, check if every function of the platform works fine.</p> <p>Torn on electricity, if everything is OK, on the frequency converter LED display should show „0.00“. This means, you can test if platform lifts up.</p> <p>On the platform, several times push button „UP“. Push and release. Repeat this step until platform reaches at least 1 meter height. Or you can go up until platform reaches second stop, by presing and holding „UP“ button.</p> <p>Now you can remove transportation pallette.</p> <p>Go down with the platform by pressing and holding „DOWN“ button until platform reaches floor.</p> <p>If this test passes, lift up the platform about 1 meter and leave it.</p>	
<p>By leaving platform lifted up, you are now able to close electrical compartment lids.</p> <p>Fit the lids together and fix them with the locking profiles. Press locking profiles with your wingers until „click“ sound.</p>	

NOTE: All palletes fixing profiles with the unlocking holes (see pic.1). Use those holes to unlock the profiles to release the panels.

To unlock profile, you need to use special tool (see pic. 2), which is located in the second stop, where all the electricity compartment located.

Just insert the tool in hole and gently push to the left or to the right. The panles locking profiles wil unlock.

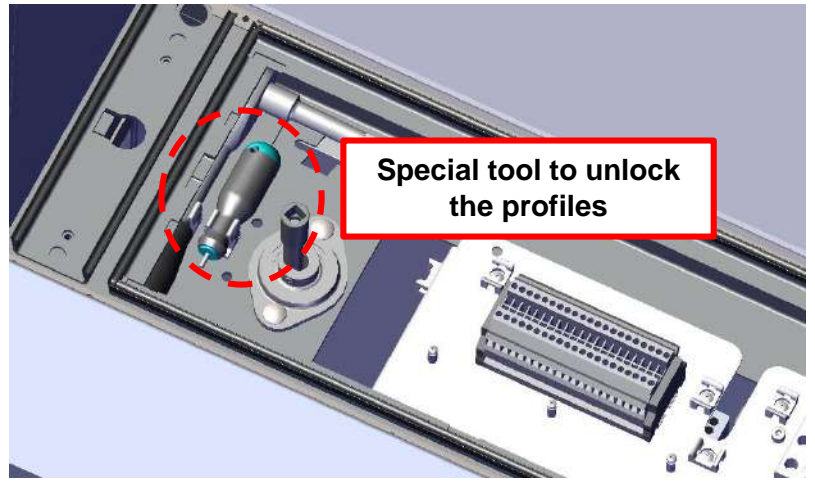
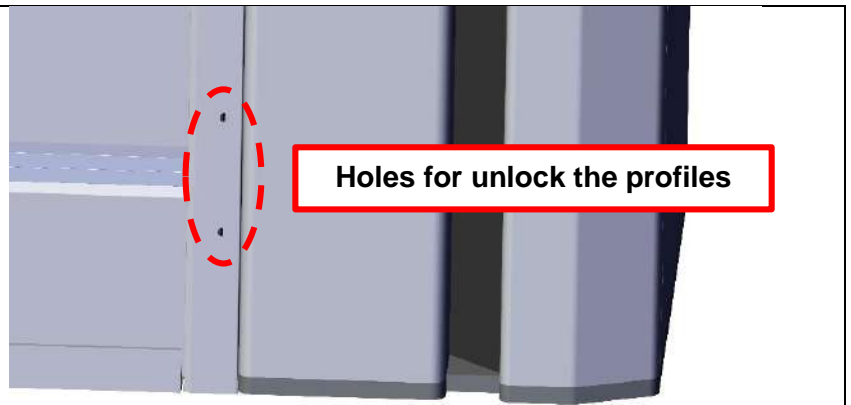

4.6. Finishing assembly of the platform lift

If all testing and electricity compartment lids are closed, you can now proceed with the rest of platform lift assembly.

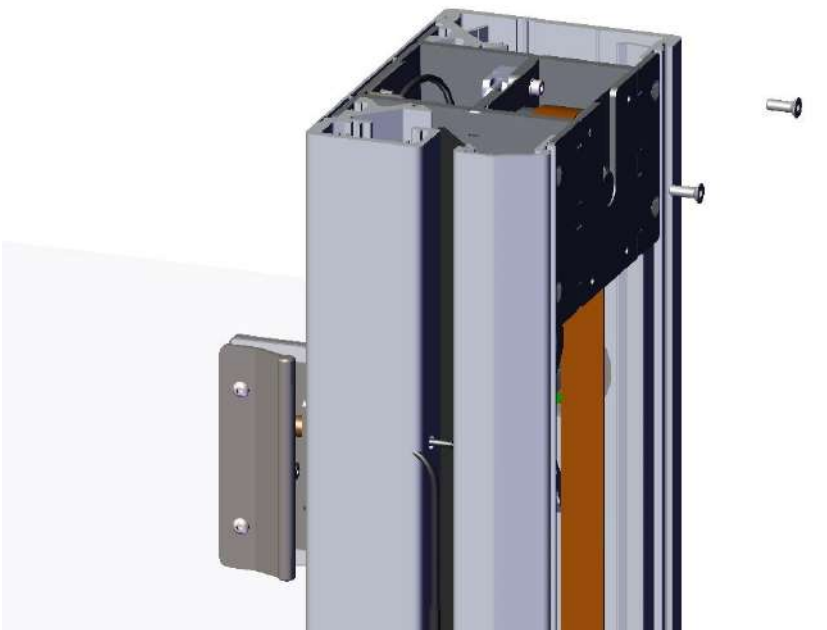
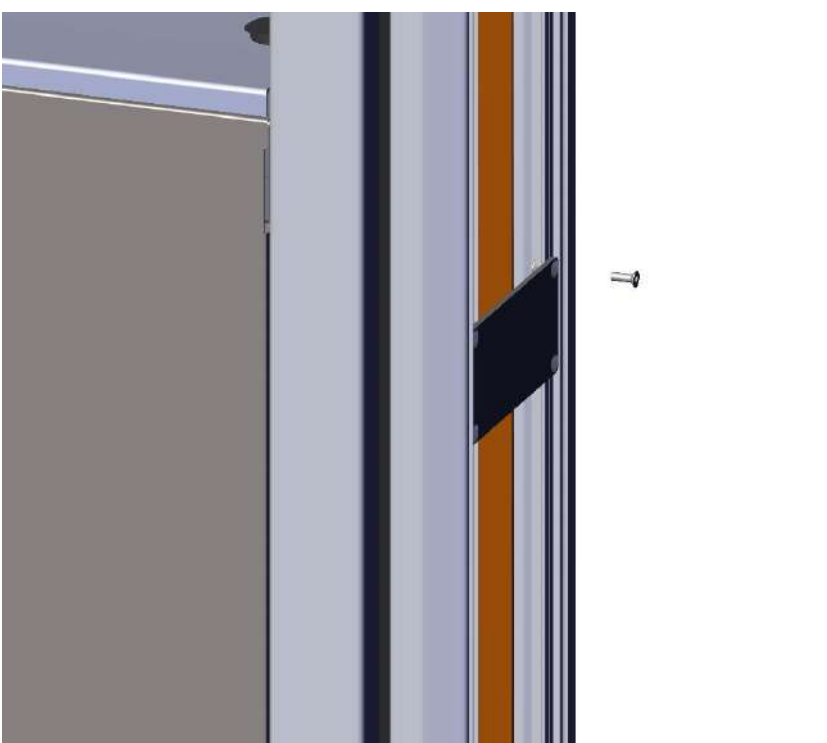
Description	Figure
<p>Tighten all 4 (four) bolts to the top of the column. This procedure is the same for both columns.</p>	
<p>Attach fixing plates to the columns. The number of plates depends of the lifting height. Please check how many these plates you received in the package.</p> <p>Plates number should be equal for both columns.</p>	

Both columns must be covered with top covers.

Attach both columns top covers with 4 (four) bolts.

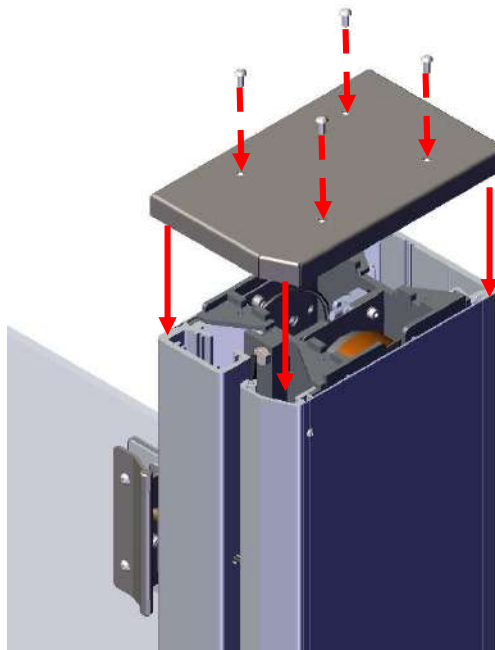

Slide in the profile side covers. Slide in holding covers about 45° degrees in relation to side columns.

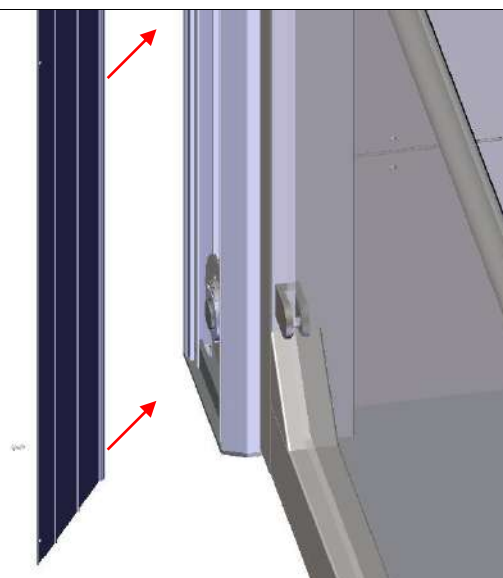

When covers slided in, now you can close them and attach with bolts.

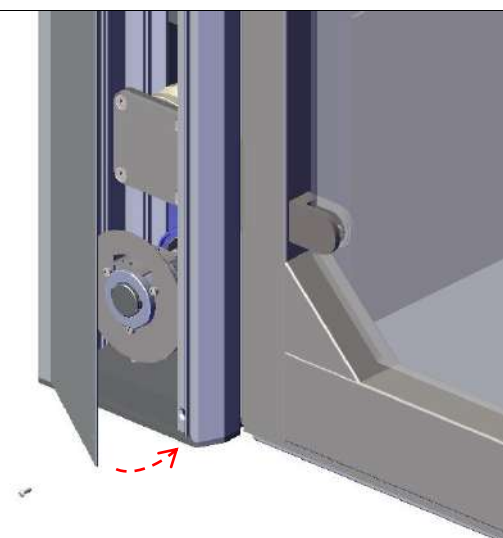

Attach bolts and tighten them. Repeat this procedure on both sides of the column construction.

NOTE: The side covers count depends on the lifting height.

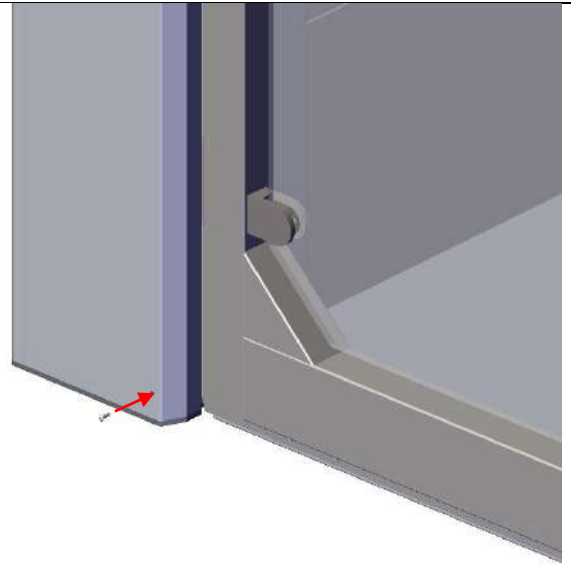

4.7. Assembled platform lift RB150

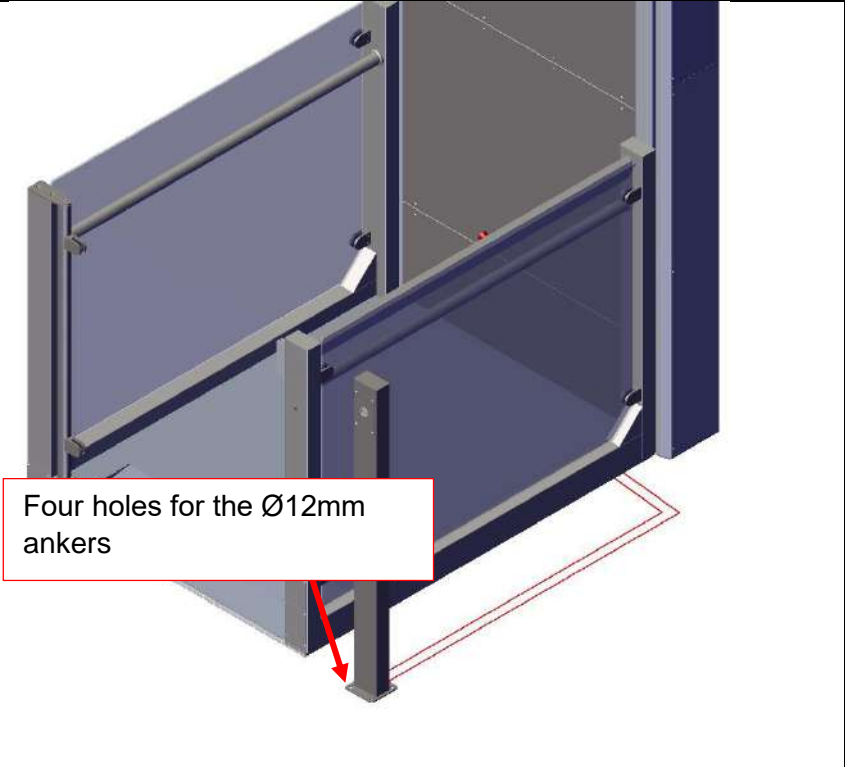
Description	Figure
<p>Final step. You have to mount „Call button column“. Decide where is the best place for it and mount it to the ground with 4 (four) Ø12mm ankers.</p> <p>NOTE: Before mounting, please make sure, that the cables is not to short from column to the mainboard. Best way to hide the cable, make groove to the cable in the floor.</p>	

Assembled platform lift RB150 should look like in the pictures.

Test all functionality, buttons, lights, call buttons, safety functions.

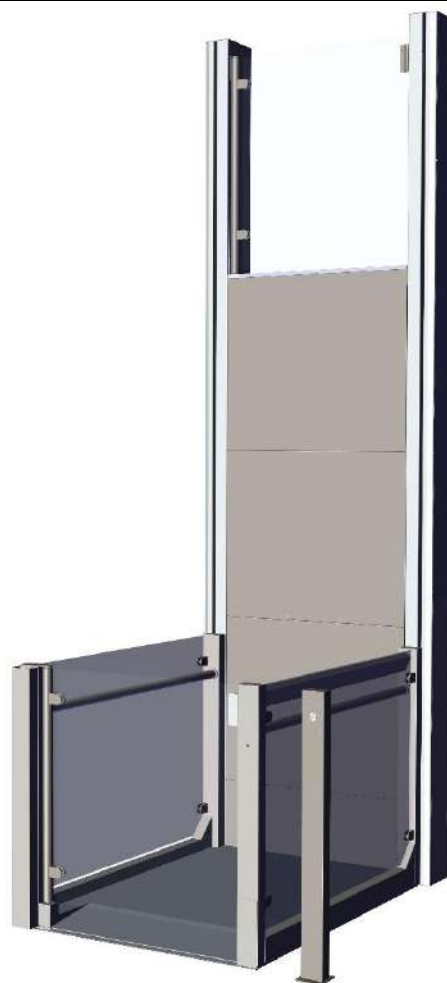



Sample of real platform lift RB150.



5. ADDITIONAL MAINTENANCE OF THE PLATFORM LIFT RB150

5.1. Gates spiral tensioning

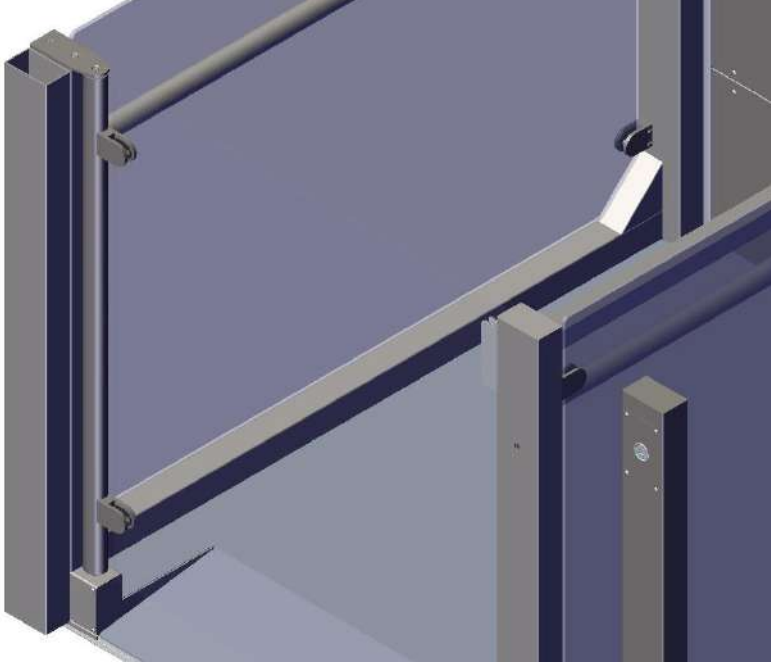
If platform lifts gates are not closing correctly, or doesn't close at all, you need to tension gates spiral. Please note, that these maintenance steps you will need at least two persons. Follow these steps:

<p>STEP 1 Drive platform to the ground.</p> <p>DON'T TENSION SPIRAL WHEN PLATFORM IS LIFTED!</p>	
<p>STEP 2 Unscrew two bolts and remove plate that holds closing gates. Other person must hold the glass gates, to ensure the gates won't fall down.</p>	

STEP 3

Slowly lift up about 10mm released glass gates, make sure they still on the lower holder.

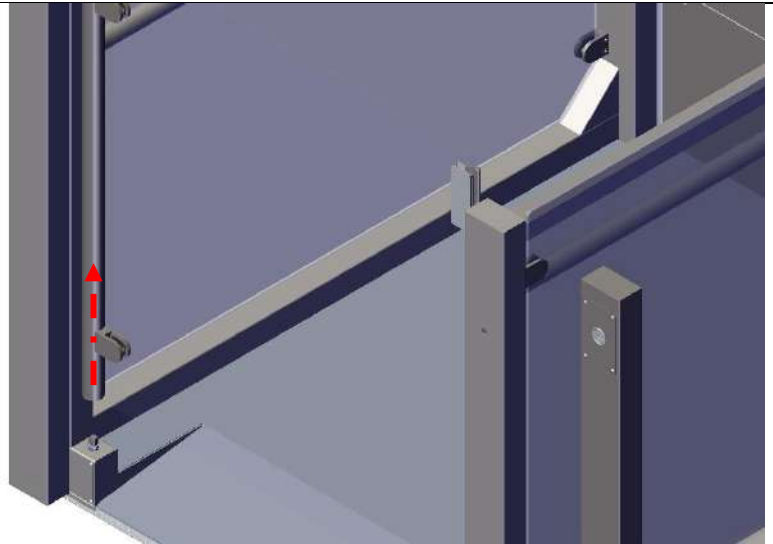
**STEP 4**

Take 13mm wrench and hold the axle. Now you can lift up the gates to make tension.

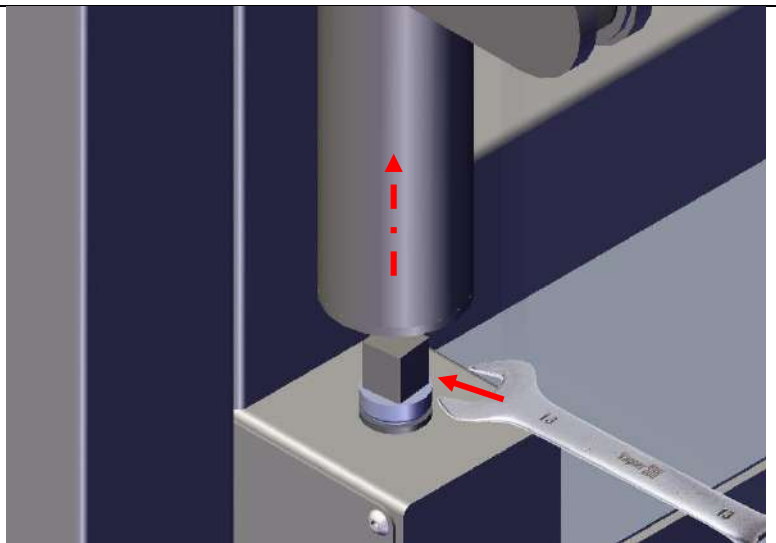
**STEP 5**

With 13mm wrench spin the axle to the left. As shown in the picture, the gates holder frame has teeth. Spin the axle to the left by one teeth and move back the door frame on the axle. Test it, if still is too loose, repeat this step for one more teeth.

After tensioning, put all parts backwards.

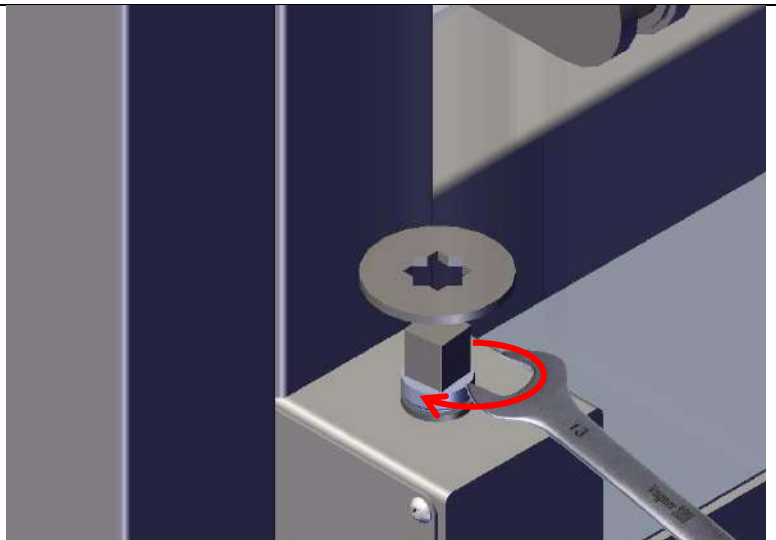

5.2. Belt gear tensioning/platform horizontal adjustment

Sometimes, because of transportation, platform of the lift RB150 needs to be adjusted horizontally, or one of the gear belts needs to be tensioned.

NOTE: Belt tensioning also adjusts platforms horizontal position, so if you tensioned only one of two belts, make sure that the platform is in perfect horizontal position.

The instruction bellow will explain how to do this part of maintenance.

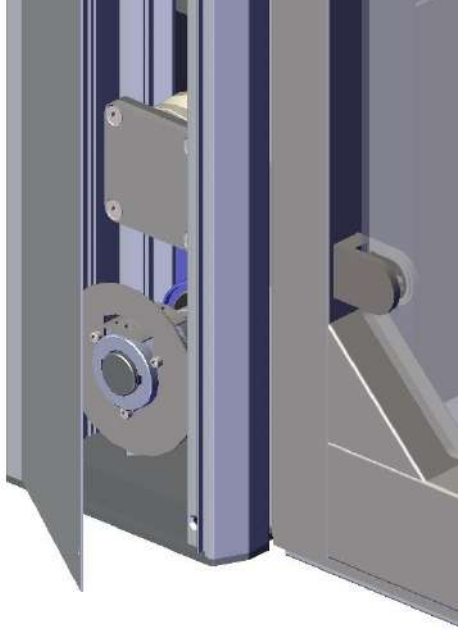
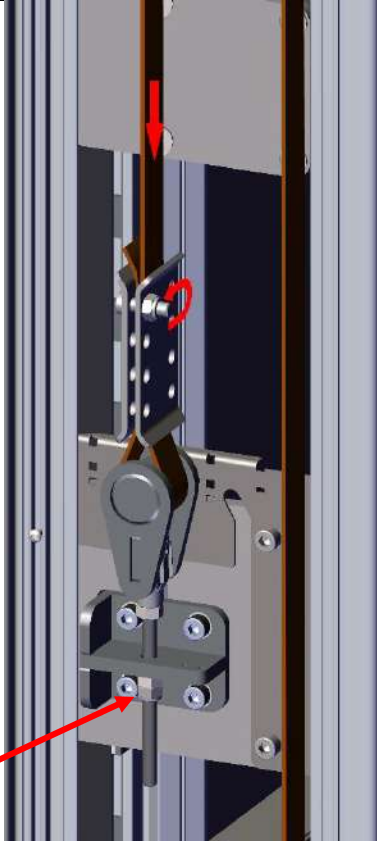
<p>STEP 1</p> <p>First, open bottom side covers. Unscrew bolts and remove covers. Now you are able to see all gear parts.</p>	
<p>STEP 2</p> <p>Release, but don't unscrew all eight bolts on the belt grip. Tense the belt down and start to screw all eight bolts back.</p> <p>TIP: Start to screw top bolt, then bottom, then middle etc.</p> <p>If tension requires only few millimeters, then you can adjust tension bolts.</p> <p>NOTE: Don't forget to fasten safety bolt when finished!</p> <p>Make sure, that in both sides of the platform belts are tensioned well.</p>	 <div data-bbox="711 1973 970 2067" style="border: 1px solid red; padding: 2px; display: inline-block;"> <p>Belt tension bolts</p> </div>

5.3. Automatic gates programming and maintenance (optional)

If you purchased open platform lift RB150 with automatic gates opening option, you should learn how to program and maintain the gates.

The self-learning means that the door automatically run a closing, opening and closing cycle in a very low speed. The door opens up to the maximum (limit of the door, wall or other possible breaches which limits the opening) and then close again until the closing.

In following openings will be automatically reduced the opening angle in a constant value to avoid the contact with the limit previously found.

It is important that the door must always start with a closing cycle.

If the closing cycle not done, check that the opening direction has been correctly selected by the first selector.

5.3.1. Self learning of „Ceitamatic“ door opener

1. Select whether the door is RIGHT or LEFT by the first selector placed up.
2. Select if the „Ceitamatic“ door opener must be controlled from the plat board by placing the selector switch to SLAVE, or it controls the movement by itself by placing selector to MASTER.
3. Press and hold pressed „SPEED“ button till it starts to flash with the door partially open in a way the door makes self-learning.
4. With button SPEED you can adjust openening and closing speed.

5.3.2. MASTER and SLAVE mode

Slave mode

1. In slave mode the ceitamatic must be controlled from the plant board
2. It will wait the signal to open (when is closed)
3. It will wait the signal to close (when is opened)
4. When it hurts something while opening it will stop waiting for a command by the pant board
5. When it hurts something while closing it will stop waiting for a command by the pant board
6. The plant board has to support the signal to give to ceitamatic

Master mode

1. In master mode the ceitamatic controls the door movements by itself
2. It will open when he received the signal (for example arrives the elevator at the floor or the button of the door is pressed or the door is manually opened)
3. It stay opened for 5 second and then reclosed (is possible to adjust the time)
4. When it hurts something while opening it will start to close
5. When it hurts something while closing it will start to open
6. Also an old control board can support the ceitamatic (easier way, just plug in)

5.4. Platform lift diagnostic via USB cable

The easiest way to find out why platform lift stopped working, or do not start after installation, is to connect platform lift's main PCB to your laptop or tablet (works only with Windows 7, 8, 8.1 and 10, and Mac) and diagnose the problem with terminal program. We suggest to use "Tera Term" (for Windows and Mac).

Diagnostic software allows you to change the locks preferences, also you will be able to check the LOG in real time, you will be able to check all safety circuit devices, to inspect what of the devices do not work correctly and after that you will be able to identify where the problem by referring to wiring diagrams.

Please follow instructions below:

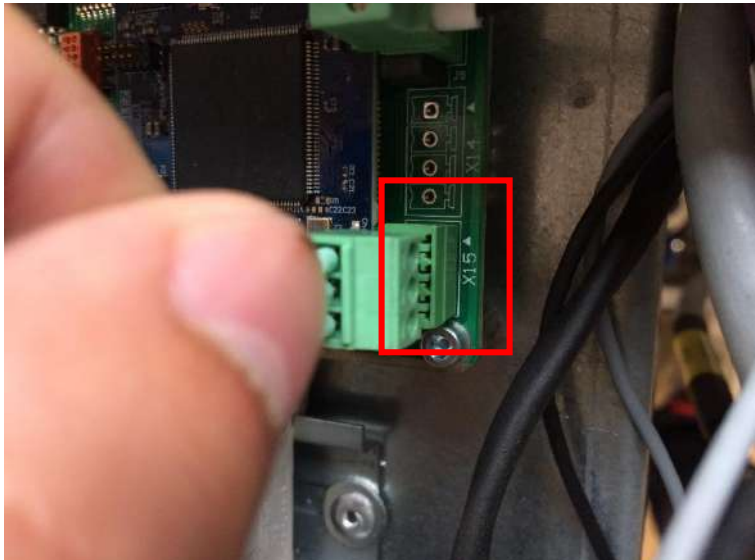
Description	Figure
<p>Download "Tera Term" software. It's free to download and it is available here: www.download.cnet.com/Tera-Term/3000-20432_4-75766675.html</p> <p>or just open "Google" and enter keywords: "Tera term download"</p> <p>Download wont took more than a few minutes.</p>	
<p>After successful download, just install "Tera Term" software to your computer and follow the instructions during the installation.</p>	
<p>VER. 1: Attach the USB cable included with platform lift RB150 to the main PCB's connection X15.</p> <p>(Please note, that we have two versions of main PCB's)</p> <p>NOTE: If you can't find any USB cable with the lift, please contact our support service: support@barduve.eu</p>	

VER. 2: Attach the USB cable included with platform lift RB150 to the main PCB's connection **X37**.

(Please note, that we have two versions of main PCB's)

NOTE: If you can't find any USB cable with the lift, please contact our support service:
support@barduve.eu

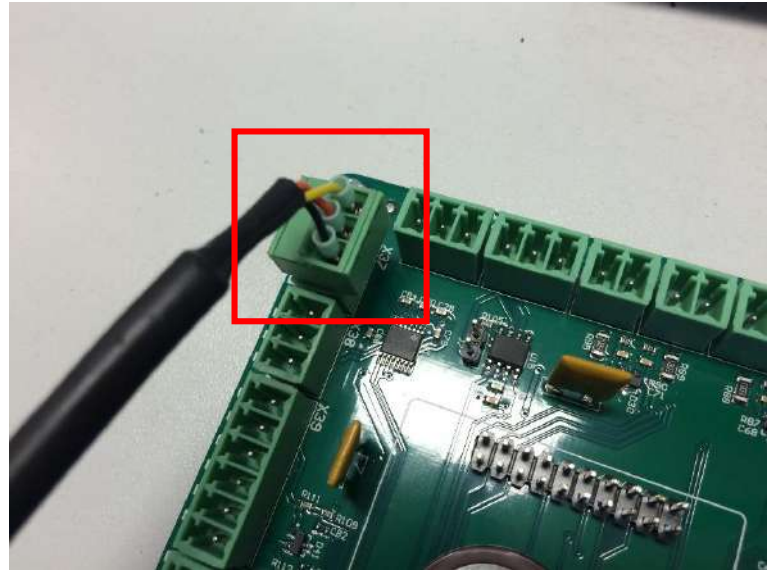

You are now able to connect USB cable to your laptop or tablet.

NOTE: very first time, your computer operating system should start installing SERIAL PORT drivers. This is normal, just wait for a few minutes.

WARNING! DO NOT INSERT USB CABLE TO YOUR COMPUTER UNTIL INSERTED TO MAIN PCB! FIRST, CONNECT CABLE TO PCB, THEN CONNECT TO USB!

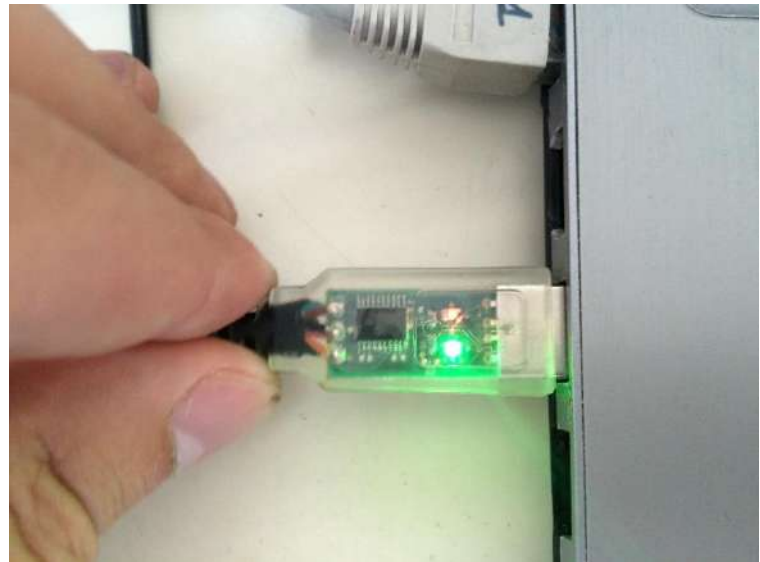

Open "Tera Term" application on your computer.

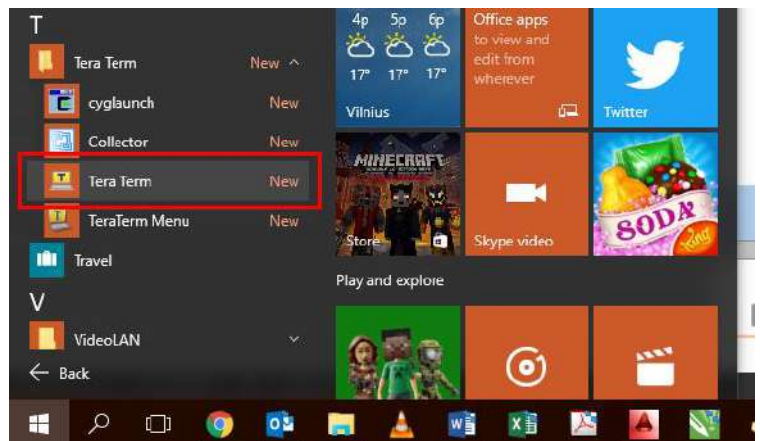

Application will start to ask what kind of port you want to use. Please select "USB serial port".

NOTE: If nothing happened, just go to:

Setup > Serial Port...

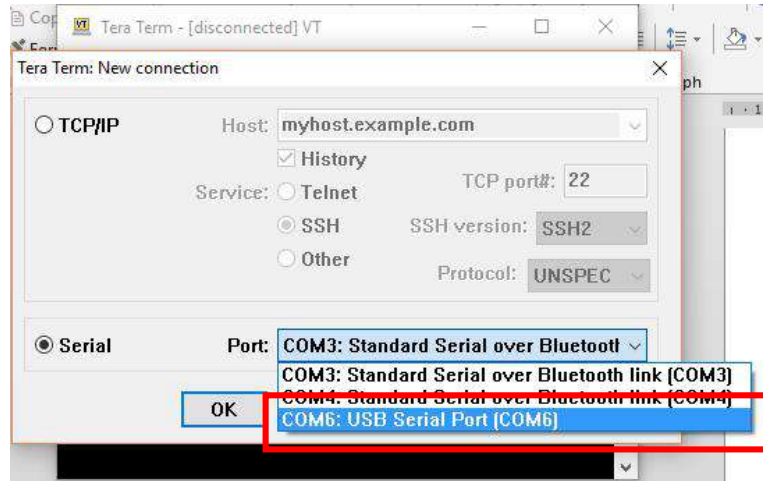

After selecting correct port, you need to setup Baud Rate of this serial port. Go to:

Setup > Serial Port...

Where "Baud Rate", type number: **1250000** and press "OK" button.

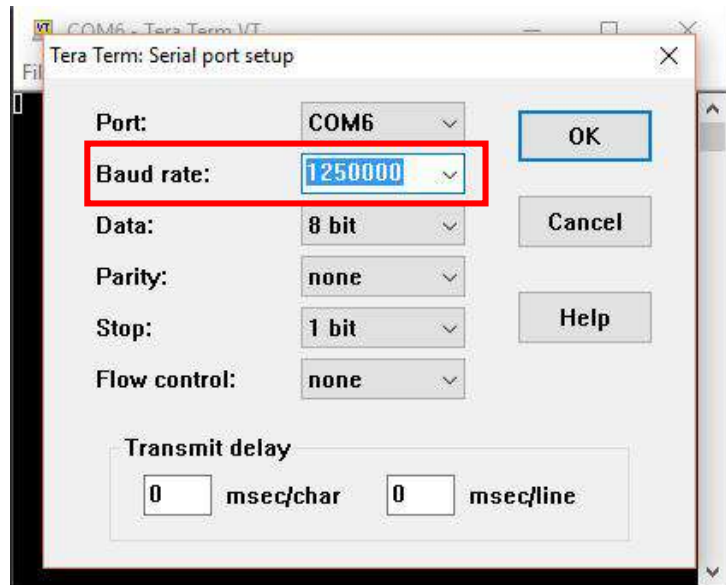

Now you are able to enter to the diagnostic program of the platform lift RB150. Follow instructions bellow

Turn the power on of the lift. You should see a window similar in the image.

Use your keyboard to enter the commands. In this screen, press “1”.

NOTE: In some versions of open platform lift RB150 software, you need to type password. If “Tera Term” displays blank window, just enter password with keyboard: **12345678** and press Enter.

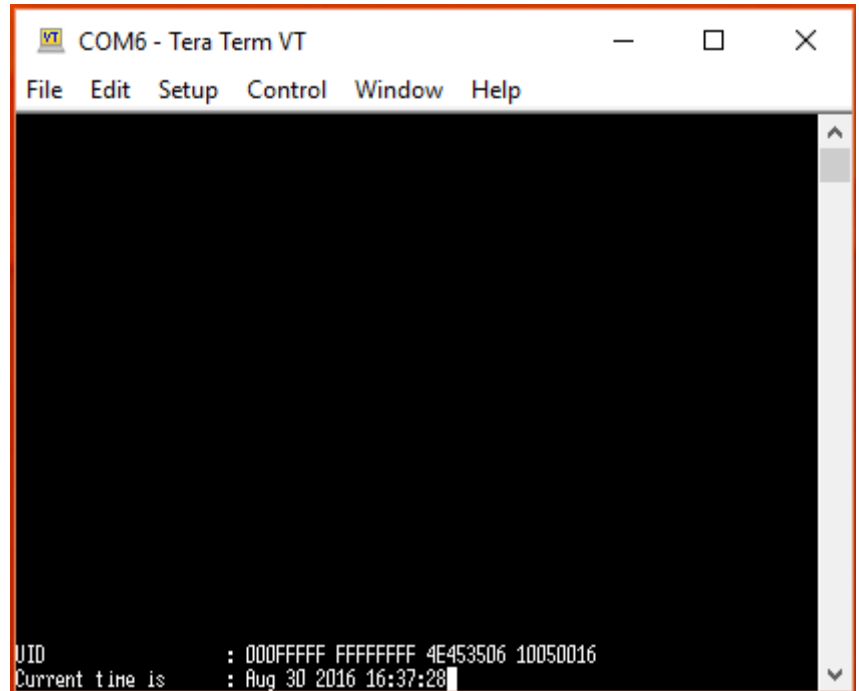

When pressed the key “1”, you are able to use simple menu. In this window, you can adjust Locks and doors, or you can jump to an expanded menu – press „M“ key.

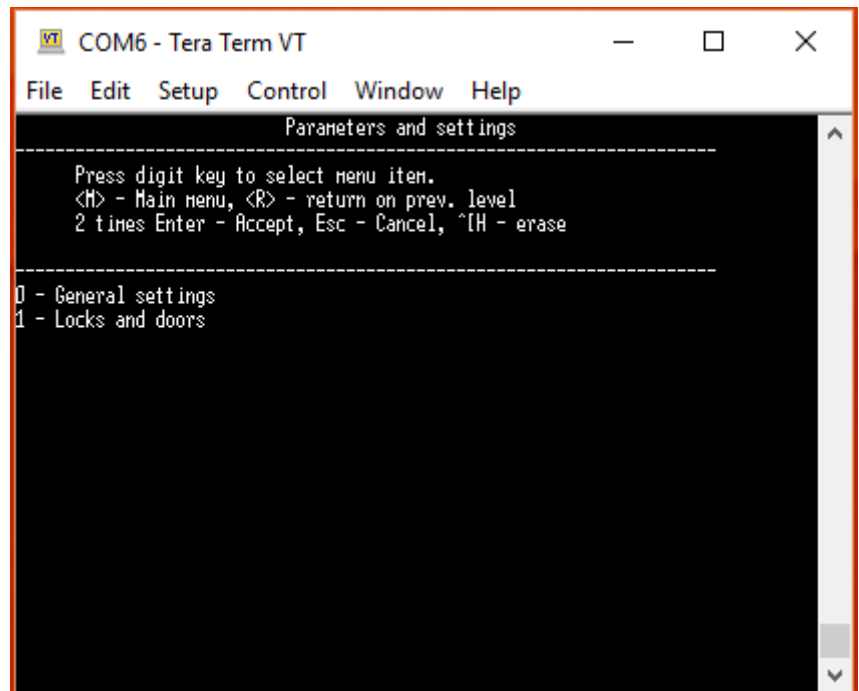

In an expanded menu you are able to adjust more settings, but here you need to focus on **<2> - System control**. Press the key "2".

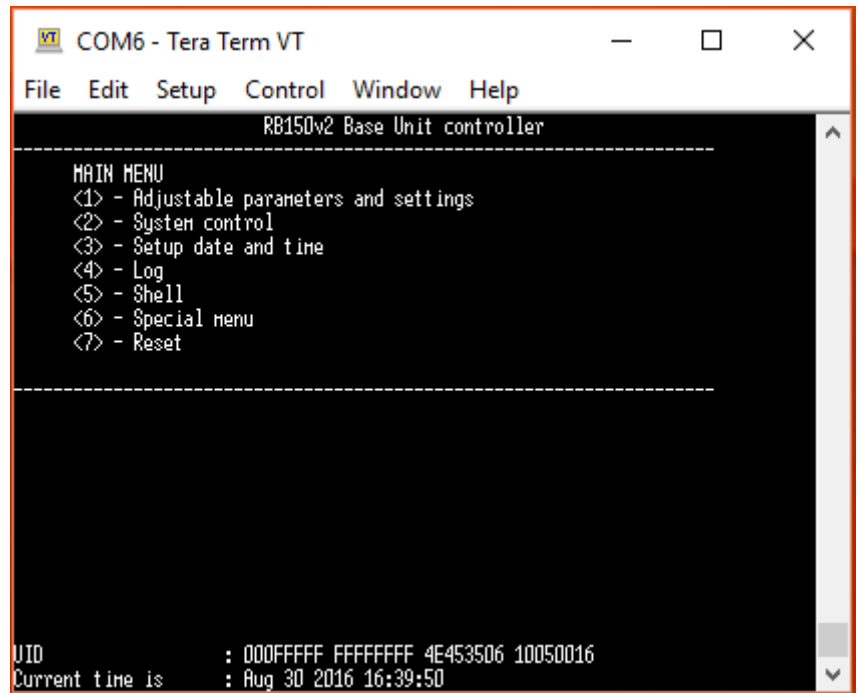

To identify where is the problem with safety circuit or maybe with logical safety devices you need to open **<1> - System state viewer**. Just press - "1".

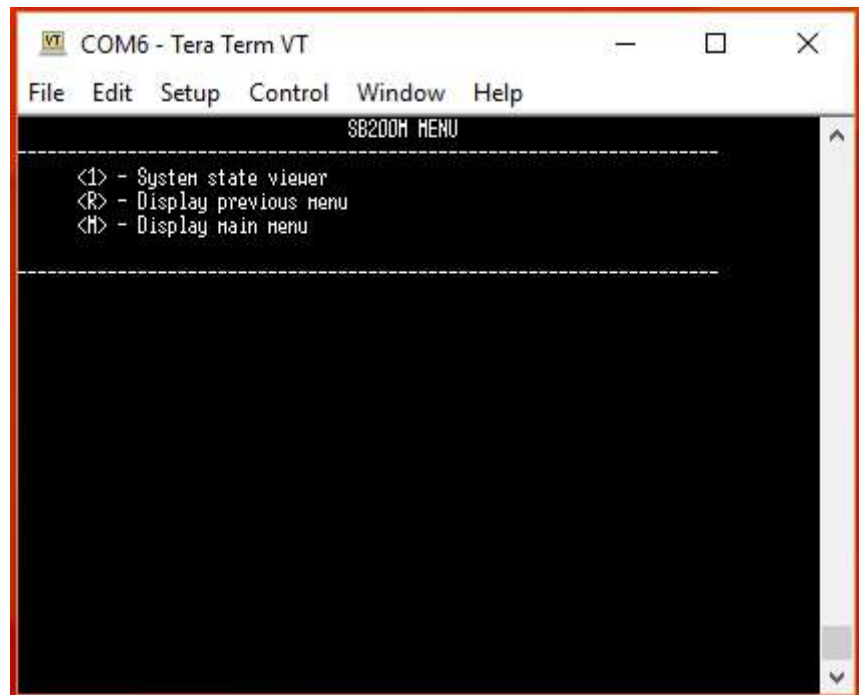

Now you can see a real time system state. In the sample, the lift doesn't move because of belt No.2 failure. We imitated this to show how identify the problem. **ESC_BELT_FAIL2= -1** – that means the belt in right side is not tight or ruptured.

NOTE: If you don't understand how identify the problem, you can make a "Screen shot" of this window by pressing keyboard buttons "**Shift+Print Screen**" (Windows);

or press buttons „**Command (⌘)+Shift+4**“ (Mac).

Paste this captured image to email window and send it to our support service: **support@barduva.eu**

Don't forget to write platform lift serial number which is located near the buttons on the platform on the coloured plate. Number starts with: R1*****

```

VT COM6 - Tera Term VT
File Edit Setup Control Window Help
Sys time= 1472575498 s State = IDLE
MAIN BOARD PLATFORM BOARD
PHR = 1 ESC7 = 0
ESC1 = 0 ESC8 = 0
ESC2 = 0 ESC9 = 0
ESC3 = 0 ESC10 = 0
ESC4 = 0 ESC11 = 0
ESC5 = 0 PRX_SW = 1
ESC6 = 0 OVL_LS = 1
ESC7 = 0 DOWN_BT = 0
ESC11 = 0 UP_BT = 0
INV_ALARM = 0 ALRM_BT = 0
ULS = 1 P_LOCKSH = 1
LLS = 1 ESC_OVSPEED1 = -1
LAND1 = 1 ESC_OVSPEED2 = -1
LAND2 = 0 ESC_STOP = -1
LOCKSH = 1 ESC_DOOR = -1
REQ1_BTN = 0
REQ2_BTN = 0
INV_BRK = 0
HOT_TEMP = 0
ESC_BELT_FAIL1= 1
ESC_BELT_FAIL2= -1
ESC_ULS = -1
ESC_DOOR = -1
ESC_STOP1 = -1
ESC_STOP2 = -1
ESC_HOTT = -1
ESC_OTHER = -1
-----LANDINGS STATE-----
Land. 0 Door= Lock= Close <-Platform
Land. 1 Door= Lock= Close
  
```

After successful problem identification, just close "Tera Term" application window and disconnect the cable from lift's main PCB and then from computer.

NOTE: DON'T DISCONNECT CABLE FROM COMPUTER USB SLOT FIRST!

5.4.1. Adjust locks and doors

To adjust doors and locks settings, you need to enter to “Locks and doors” menu.

To do that, follow the instruction in paragraph 5.4.

```

VT COM6 - Tera Term VT
File Edit Setup Control Window Help
Locks and doors
-----
Press digit key to select menu item.
<M> - Main menu, <R> - return on prev. level
2 times Enter - Accept, Esc - Cancel, ^H - erase
-----
0 - Opened lock timeout(s) = 10
1 - Contacts bounce timeout(ms) = 300
2 - Automatic door closing timeout(s) = 30
3 - Not to close the 1-st floor lock when door are open = 0
4 - Not to close the 2-nd floor lock when door are open = 0
    
```

In this example we need to change automatic (optional) door openers parameters. By default, automatic door opener closes the door after 30sec. In this case, we want that door opener stay open until call button is pressed.

Press “3” keyboard button. Delete the parameter “0” and enter parameter “1”.

To enable this setting press “Enter” button TWICE.

```

VT COM6 - Tera Term VT
File Edit Setup Control Window Help
Locks and doors
-----
Press digit key to select menu item.
<M> - Main menu, <R> - return on prev. level
2 times Enter - Accept, Esc - Cancel, ^H - erase
-----
0 - Opened lock timeout(s) = 10
1 - Contacts bounce timeout(ms) = 300
2 - Automatic door closing timeout(s) = 30
3 - Not to close the 1-st floor lock when door are open = 0
4 - Not to close the 2-nd floor lock when door are open = 0
-----
Edited parameter: ' Not to close the 1-st floor lock when door are open '
>1
    
```

As you can see, parameter has been changed.

Repeat this example to adjust your lift by your desired settings.

```

VT COM6 - Tera Term VT
File Edit Setup Control Window Help
Locks and doors
-----
Press digit key to select menu item.
<M> - Main menu, <R> - return on prev. level
2 times Enter - Accept, Esc - Cancel, ^H - erase
-----
0 - Opened lock timeout(s) = 10
1 - Contacts bounce timeout(ms) = 300
2 - Automatic door closing timeout(s) = 30
3 - Not to close the 1-st floor lock when door are open = 1
4 - Not to close the 2-nd floor lock when door are open = 0
    
```

5.5. Adjusting door closing sensors

Sometimes, after open platform lift RB150 transportation, door closing sensors not working fine. Possible issues:

- When doors is closed, the lock starts to open and close continuously.

To solve this problem, follow the instructions bellow:

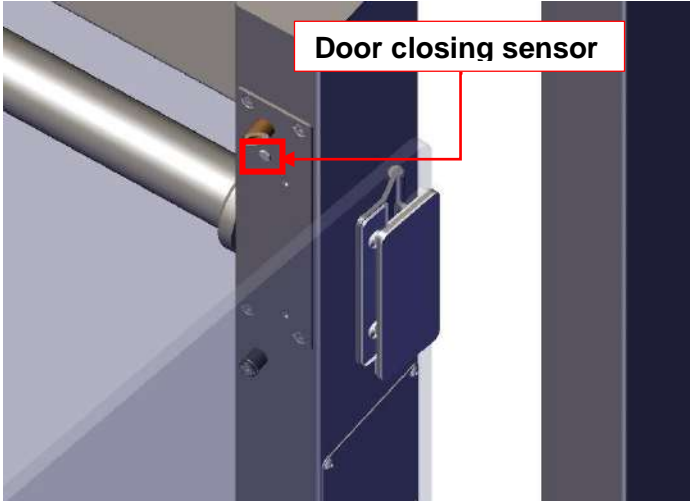
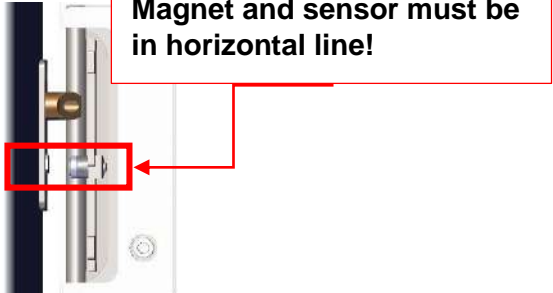
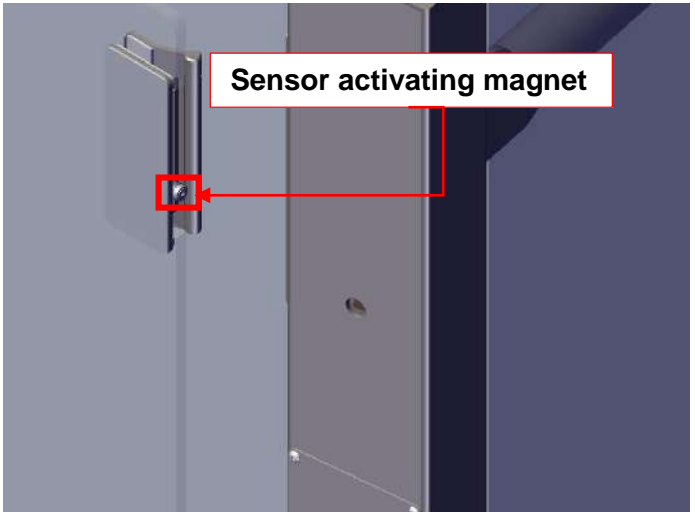
Description	Figure
<p>Each open platform lift RB150 has door closing sensors. This sensor identifies if the doors is closed or not. Sensor activates and disactivates by magnet, which is located in the doors handle.</p>	 <p>Door closing sensor</p>
<p>Magnet and sensor must be in horizontal line, wen doors is closed! If magnet a little bit slided down or up, you must fix it by sliding the magnet to its normal position.</p>	 <p>Magnet and sensor must be in horizontal line!</p>
<p>To slide the magnet, open the doors and untighten the magnets screw. Do not unscrew it completely, it needs only untighten.</p> <p>Check the position by closing the doors, if still the magnet not in right place, repeat this step once again.</p>	 <p>Sensor activating magnet</p>

8. IMPORTANT NOTES FOR INSTALLERS

OPEN PLATFORM LIFT RB150 (VER.1)

SWITCH ON INSTRUCTIONS (AFTER INSTALLATION)

Before switching on platform lift RB150, please make sure all of following steps are completed:

- ▶ Check the belts tension - they must be tight, otherwise the lift won't operate!
- ▶ Check emergency lowering system. It must be enabled to normal operation (green handle must be turned on).
- ▶ Make sure the platform is not lying on the ground before switching power on. On the platforms bottom there is safety edge, which can not be activated, otherwise the lift won't work. Platform should be „in the air“ at least 2cm before first start. You can lift it up by belt tensioning nuts in both sides of the columns.
- ▶ Make sure that both gates (upper and bottom) is securely closed before lifting up the platform with „UP“ button
- ▶ Make sure that both (bottom and upper emergency limit swithes) are not turned on!

If all of these steps are completed, switch on the power and press button „UP“. The platform lift should work normaly.

If you have any problems and the lift is still not running, try to override the safety circuit with **J2** jumper on main board, which is located in the upper levels step (pic.1):

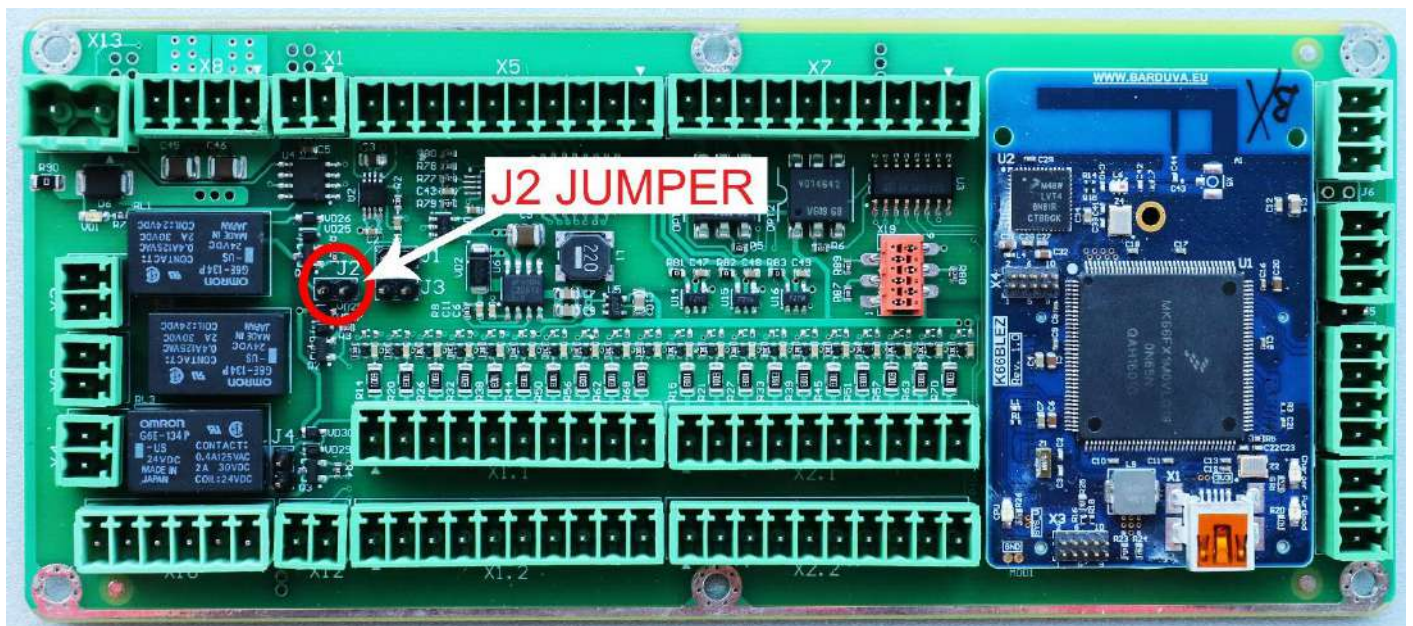

OPEN PLATFORM LIFT RB150 (VER.2)

SWITCH ON INSTRUCTIONS (AFTER INSTALLATION)

Before switching on platform lift RB150, please make sure all of following steps are completed:

- ▶ Check the belts tension - they must be tight, otherwise the lift won't operate!
- ▶ Check emergency lowering system. It must be enabled to normal operation (green handle must be turned on).
- ▶ Make sure the platform is not lying on the ground before switching power on. On the platforms bottom there is safety edge, which can not be activated, otherwise the lift won't work. Platform should be „in the air“ at least 2cm before first start. You can lift it up by belt tensioning nuts in both sides of the columns.
- ▶ Make sure that both gates (upper and bottom) is securely closed before lifting up the platform with „UP“ button
- ▶ Make sure that both (bottom and upper emergency limit swithes) are not turned on!

If all of these steps are completed, switch on the power and press button „UP“. The platform lift should work normaly.

If you have any problems and the lift is still not running, try to override the safety circuit with **J6** jumper on main board, which is located in the upper levels step (pic.1):

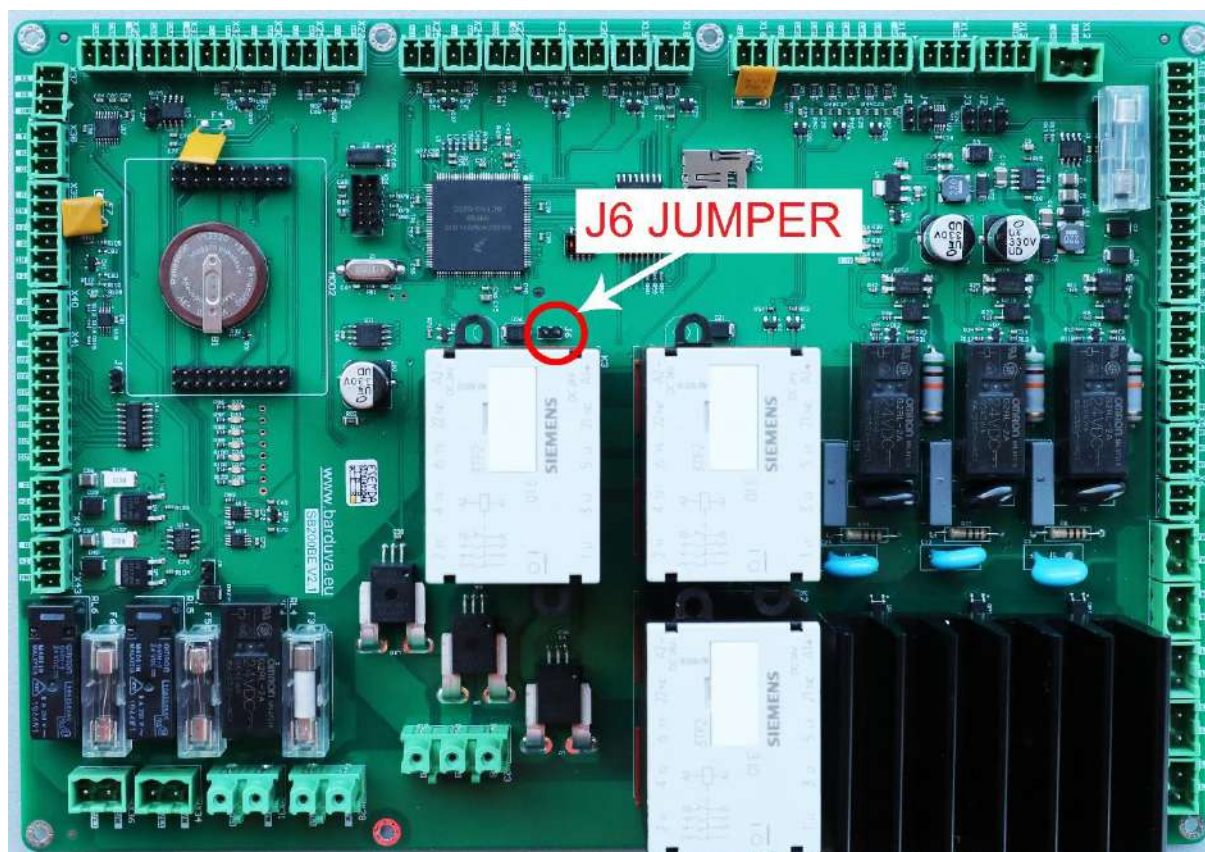

8. ELECTRICAL SCHEMES

All electrical schemes including scheme of call button connection (SEE NEXT PAGE).