

# **INSTALLATION MANUAL**

## **Vertical lifting platform AB300**

**Manufacturer** **BARDUVA JSC**  
Beržuonos str. 2  
LT-02121, Vilnius  
Lithuania  
Tel. +370 5231 0770  
Fax. +370 5231 0773  
E-mail. [sales@barduva.eu](mailto:sales@barduva.eu)  
[www.barduva.eu](http://www.barduva.eu)

**Service line** Tel. +370 5231 0770  
E-mail. [support@barduva.eu](mailto:support@barduva.eu)

**Date of issue** 2022-03-15

**Author** GP

**Release** 3.0/24-04

**Revision** 3

**Doc. No.** AB300-INST-EN-1

**Copyright** © - Barduva, 2024

No part of this publication may be reproduced, distributed or made available to the public without the written permission of JSC Barduva

## Revision overview

<b>Revision</b>	<b>Date</b>	<b>Summary of revision</b>
-	15-03-2022	Original
1	10-10-2022	3.7. Installation of self rescue rope 3.10. Installation of belts 4. Wiring and cable managing 5.3. Placing rescue instructions
2	15-06-2023	3.0. Assembly of a lift
3	04-04-2024	3.2. Guide rails 3.4. Over speed governor 3.10. Installation of control system elements

# Table of Contents

.....	1
1. Important safety instructions.....	4
1.1. General.....	4
1.2. Safety regulations.....	4
1.3. Electromagnetic compatibility (EMC).....	4
1.4. Handling electronic assemblies.....	4
1.5. Personnel qualifications.....	4
1.6. Danger notices.....	4
1.7. Warning signs.....	5
1.7.1. Possible hazard situations.....	5
1.7.2. Electrical hazards.....	5
1.7.3. Personal safety equipment.....	5
1.7.4. How to contact us.....	5
2. Preparation for installation.....	6
2.1. Base.....	6
2.2. Tools and equipment required for installation.....	6
2.3. Parts list verification.....	6
2.4. Unpacking.....	6
2.5. Shaft openings straightness check.....	6
3. Assembly of a lift.....	7
3.1. Bottom frame.....	7
3.2. Guide rails.....	9
3.3. Installation of emergency guide rail.....	13
3.4. Over speed governor.....	14
3.5. Installation of a pit prop.....	16
3.6. Position sensors.....	17
3.7. Platform.....	18
3.8. Installation of belts.....	21
3.9. Encoder stripe installation.....	23
3.10. Installation of control system elements.....	24
4. Wiring and cable management.....	26
5. Lift shaft and doors.....	29
5.1. Lift shaft assembly.....	29
5.2. Doors.....	30
5.2.1. Planks under and above the doors.....	32
5.2.2. Placing the rescue instructions.....	32
5.2.3. Installation of door canopy (if any).....	32
5.3. Installation of self rescue rope.....	33
5.4. Assembly of a ceiling.....	34
6. Assembly of guard wall.....	35
6.1. Inner panel wall.....	35
7. Assembly of a roof (Outdoor option).....	37
8. Landing preparation for use.....	40
8.1. Landing height programming.....	40
8.2. Door contact and lock latch adjustment.....	41
8.3. Hydraulic door closer adjustment.....	43
8.4. BAR Automatic door opener calibration (optional).....	44
9. Installation of Reinforcing bracket (optional).....	45
10. Checklist.....	50

# 1. IMPORTANT SAFETY INSTRUCTIONS

## 1.1. General

Please read this manual carefully before installing the AB300.

This manual contains the important information on safe installation.

Local, national and on-site regulations regarding safe installations and protection shall be taken into account in addition with this manual.

## 1.2 Safety regulations

The lift AB300 was designed with accordance to EN81-41.

The AB300 may only be operated in perfect working condition in proper manner, safety and in compliance with the manual, the safety regulations.

## 1.3. Electromagnetic compatibility (EMC)

The AB300 complies with the standards:

EN12016:2013

EN 61000-4-3-2006

EN 61000-4-3-2006/A1:2008

EN 61000-4-3-2006/A2:2010

## 1.4. Handling electronic assemblies

Keep the electronic assembly in its original packaging until installation to prevent damage.  
Before opening

## 1.5. Personnel qualifications

Only the qualified personnel can install the lift.

Electrical connection must be done by a competent electrician.

People who are not involved shall not be allowed in the assembling area.

## 1.6. Danger notices

Do not install lift on foundation of unknown strength, first make sure of the strength of the base.

Read and understand all the safety warnings before starting the assembly of each element.

Keep hands and feet away from any moving parts.

Do not wear unsuitable clothing which parts could be caught by moving parts of a lift.

Clean up the surrounding area from unnecessary items.

Before working under the lift platform always engage the pit pop.

Never remove safety related components from a lift.

Discontinue work if safety components are damaged or missing.

Check at any time the parts of the lift to ensure the agility of moving parts and the performance of elevation.

Before interrupting the installation work lower the lift to its lowest position and do remember to cut off the power source.

Do not modify any parts of the lift without manufacturer's advice.

Disconnect the power source if you noticed any signs of malfunction.

## 1.7. Warning signs

Prior starting the assembly of a lift and during installation, it must be taken all necessary actions to avoid dangerous and hazardous situations to the persons or the environment.

An installation of a lift must be performed only by skilled personnel.

These personnel must be thoroughly familiar with the instructions contained in this manual and must also be familiar with the national regulations for safety and general accident prevention in each country in accordance with national laws.

### 1.7.1. Possible hazard situations

- **Work at height:** corresponding safety measures have to be taken to guarantee the safe work at height. Depending on the domestic laws use appropriate hoisting equipment, etc. ladders, scaffolds, scissor lift or similar;
- **Heavy parts:** some of the platform lift parts are heavy, so it is important to lift it up by two persons or in some cases use hoisting equipment;
- **Danger zones:** secure the assembly area and area near it with signs and / or other warning signs, restriction materials;
- **Falling things:** never work under the platform, if there is a person already working on it. Before entering the shaft make sure that shaft components are fixed properly;

### 1.7.2. Electrical hazards

Symbol	Hazardous situation
	The electrical shock possibility in the machine room and / or near the lift parts containing electrical components!

In order to avoid the accidents, all the electrical installation work shall be carried out by skilled personnel, as stated in the national laws..

Machine room cover shall be closed and locked all the time, when the work in the electrical compartment is not being carried out.

### 1.7.3. Personal safety equipment

	Wear personal safety equipment: safety shoes, gloves, helmet, safety glasses, earplugs, etc.
---	--

It is very important to use personal safety equipment during the installation and also using the installation tools and machines to avoid personal injuries.

### 1.7.4. How to contact us

If you need to contact our support service, please keep the following information:

Tel.: +370 5231 0770

Mail.: [support@barduva.eu](mailto:support@barduva.eu)

## 2. PREPARATION FOR INSTALLATION

### 2.1. Base

A lift is to be installed on a smooth and solid concrete base with a strength of at least 20 MPa (C20/25) and with the minimum thickness of 200 mm. The base flatness tolerance shall not exceed 5 mm. It is recommended that freshly poured concrete shall undergo 28 days' aging to achieve the rated strength.

### 2.2. Tools and equipment required for installation

- Electric drill with drill kit for metal construction and concrete construction;
- Hammer drill;
- Cordless screw driver with adjustable tightening torque;
- Level;
- Multimeter;
- Disc saw with disc;
- Laser distance meter;
- Plumb-line (plumb-line length depends on lift shaft height);
- Nylon rope;
- Hammer;
- Pencil;
- Tape-measure;
- Adjustable torque wrench (20 Nm - 200 Nm);
- Riveting device;
- Wrench kit;
- Flat file;
- Clamps, 2 pcs.

### 2.3. Parts list verification

Verify with the detail list if all the parts are present.  
Contact the dealer if any parts are missing.

### 2.4. Unpacking

Carefully unpack all the components.

In order not to scratch the painted surfaces it is recommended to work in pairs.

Thoroughly check the consignment for any possible damages or missing parts right after reception.

If there are any problems regarding the consignment notify the dealer. Complaints received long time after the reception of the consignment may not be accepted.

### 2.5. Shaft openings straightness check

Check the travel distance and the dimensions of shaft openings on the floors.

If the platform lift is to be installed in an existing shaft, check if the walls do not incline into the future shaft projection.

### 3. ASSEMBLY OF A LIFT

#### 3.1. Bottom frame

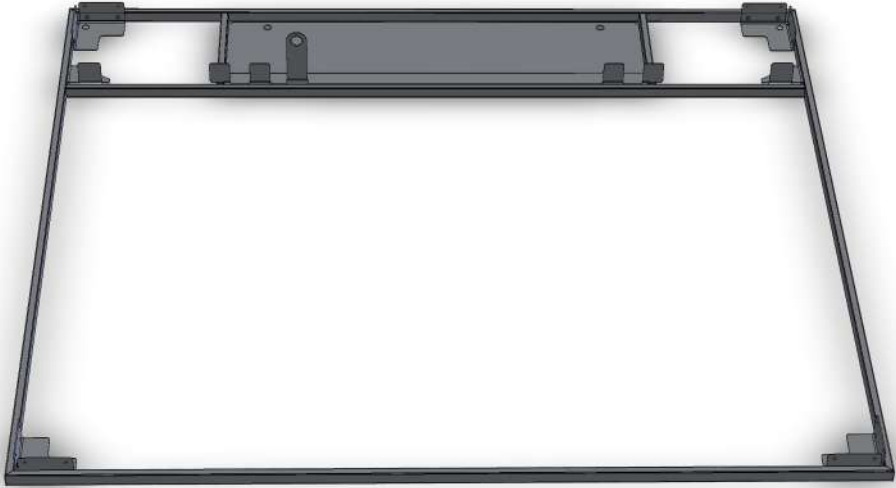
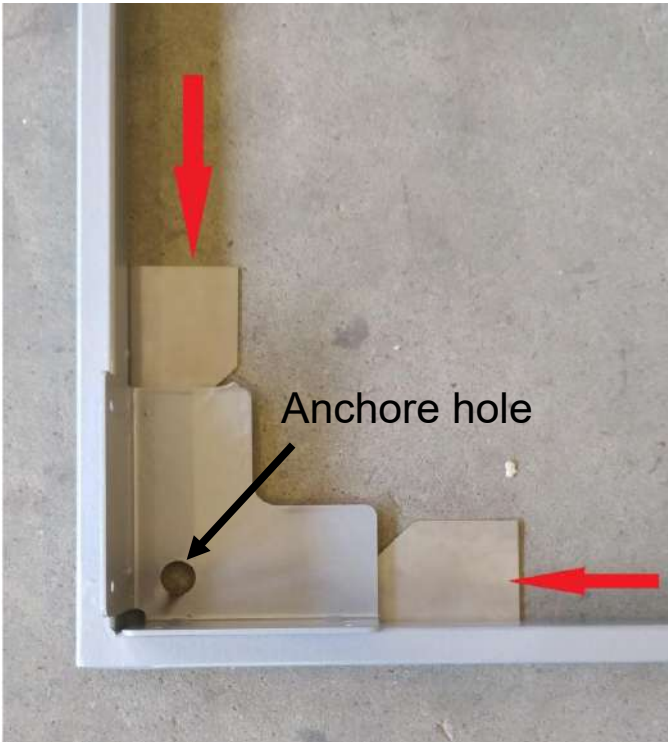
Step	Job description
1	<p>Place the bottom frame into a place (pit).</p> 
2	<p>For better determination of correct position of the bottom frame, sink the plumb bob level from the top landing and check whether the string descends to the bottom not interfering the structural elements of a building. Move the frame to avoid the plumb bob from touching anything.</p>
3	<p>Check the horizontality of the lower frame with a level and align if required with the leveling plates. The leveling plates are to be placed and dipped underneath the frame so that not to cover the anchor's holes at the corners as it is shown in the picture.</p> 

- 4 Drill 8 holes with diameter of 12 mm to the depth of 130 mm in to concrete floor at locations shown in picture. Holes in the bottom frame are prepared in advance. Fasten the frame at first at four points along the perimeter (green arrows).

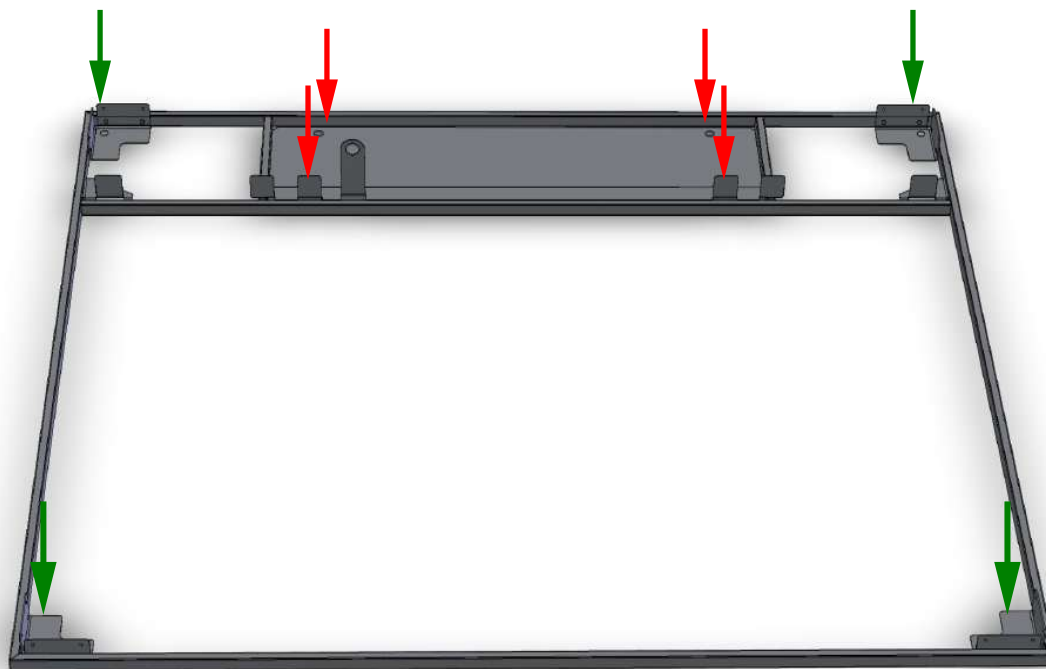

- 5 Bring the motor-reducer assembly to the bottom frame, insert it into the recess in the frame so that the anchoring holes coincide, and anchor the frame together with the motor assembly to the base (red arrows).

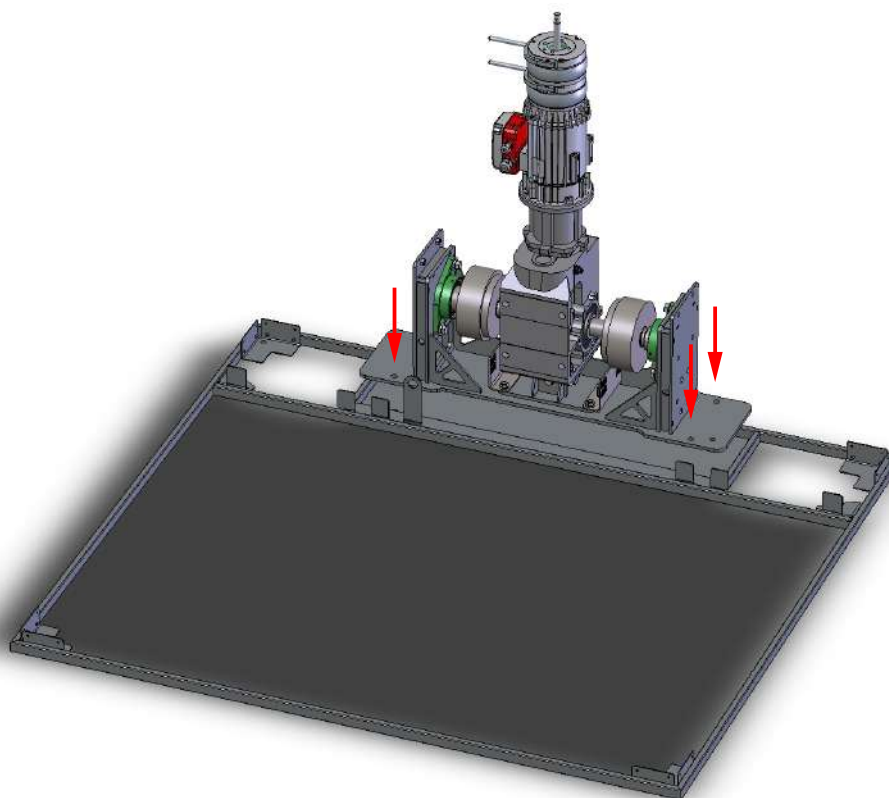

### 3.2. Guide rails

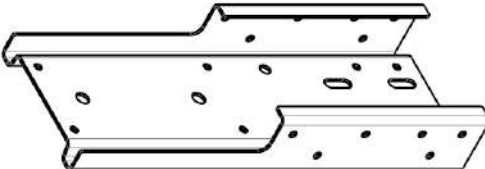
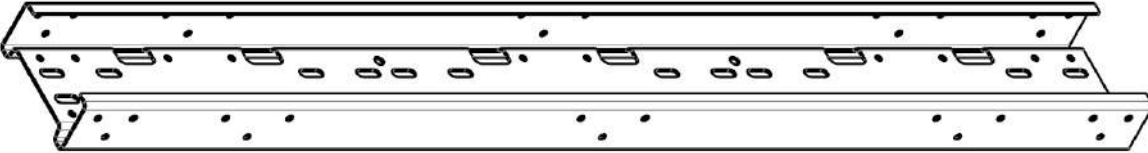
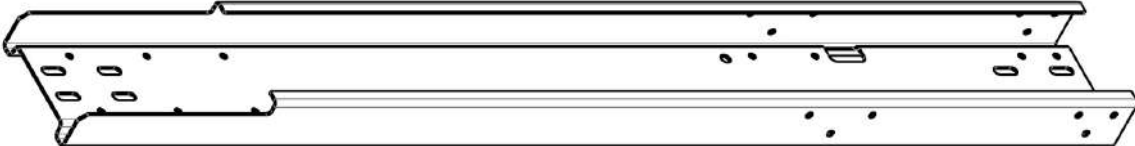
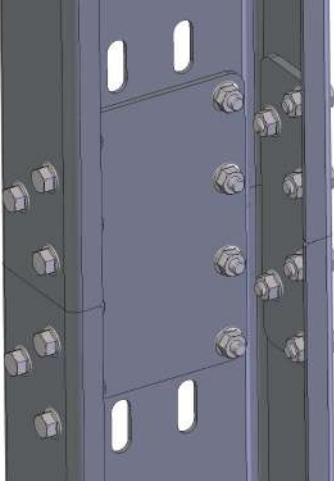
Step	Job description
1	<p data-bbox="252 293 635 322">Sort out the guide rail elements.</p> <p data-bbox="788 362 970 392">Upper element</p>  <p data-bbox="587 719 1169 748">Intermediate element (all equal and symmetrical)</p>  <p data-bbox="788 1012 970 1041">Lower element</p>  <p data-bbox="252 1341 1259 1406">Notes: The lower and the upper elements have the characteristic cut-outs at the end. The length of the top element depends on the height of the elevator.</p>
2	<p data-bbox="252 1429 1497 1525">The picture bellow shows the method of joining of the rail elements: apply the inserts from an inside, use flange bolts M8x20, and nuts. A total of 20 bolts is to be applied for a single connection. It is recommended to connect the lower element with the intermediate element in advance.</p> 

3

Put the lower guide rails element (may be assembled with the following guide rail element) to the motor-reducer assembly as shown in the picture and fasten with 6 bolts M8x20 with nuts. Repeat with the opposite side.

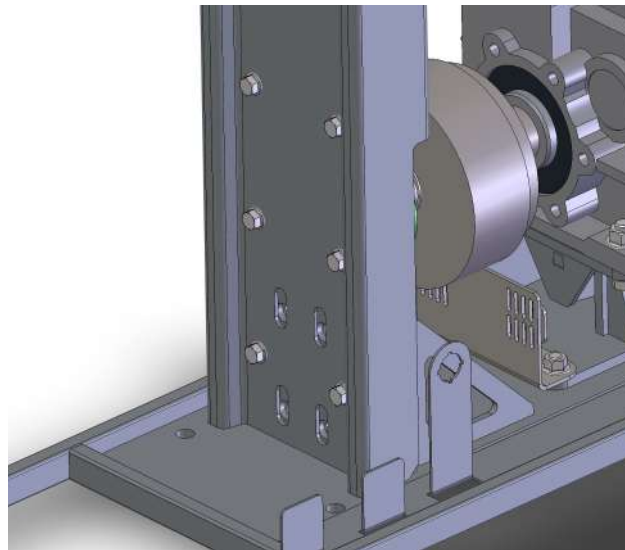

ⓘ

**Guide rails's elements are heavy, carry the guide rails carefully by two!**

4

The guide rails are interconnected with each other and fixed with the building as it is shown in the picture. To find out at what heights you need to place crossbars and fixings with the building, check in the general frame drawing.

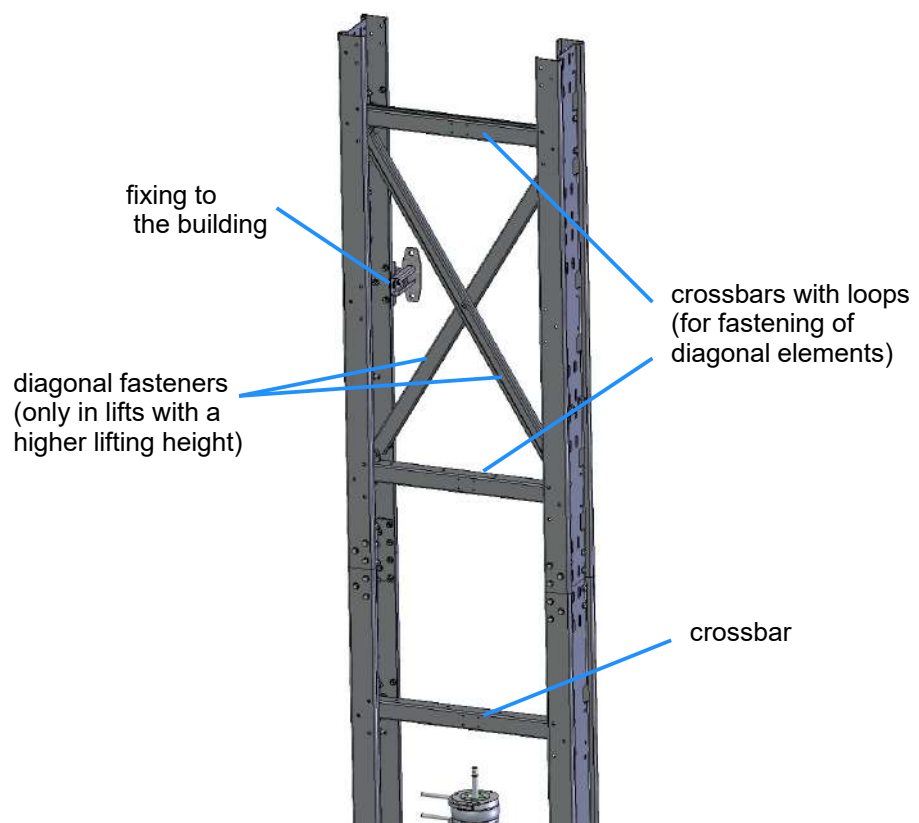

- 5 Install the lift shaft corner profiles holder beams. Use bolts M8x20. A total of 4 bolts for each beam. Check the fastening points in the general drawing of the frame construction

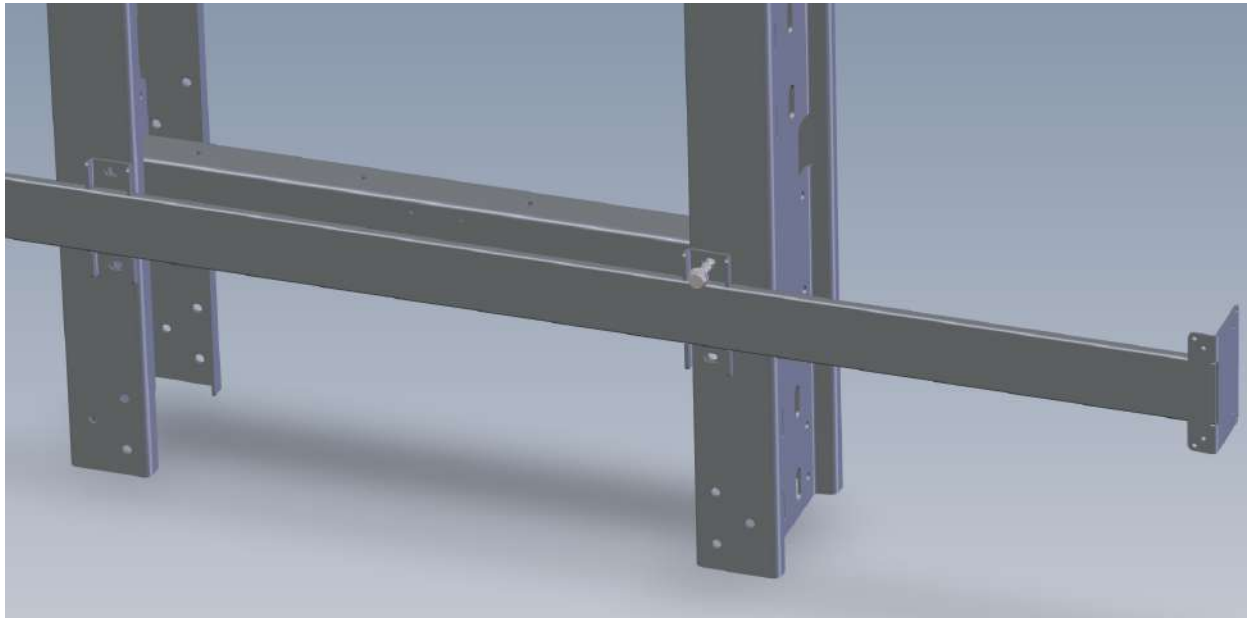

Rear view

**ⓘ Beware of falling parts when extending guide rails!**

- 6 If guide rails structure has diagonal elements, the crossbars which hold the diagonal elements have the ears for fastening the diagonal truss elements. Make sure that the ears were pointing towards each other.

- 7 If the lift is attached to the building via fixings on the rails\*, this can be done through the wall on the B side. Attach the brackets to the rails at an intended locations on the back side of guide rails as it is shown in the picture. Use three bolts M8x20x20 and nuts M8. Connect with an opposite part, mark the places for the holes on the wall, drill and fix. The anchors supplied by the manufacturer are suitable only for silicate masonry. Otherwise, it is recommended to consult with the construction specialist. The fixing element is adjustable, so the final tightening is recommended after the rails are fully assembled and level.

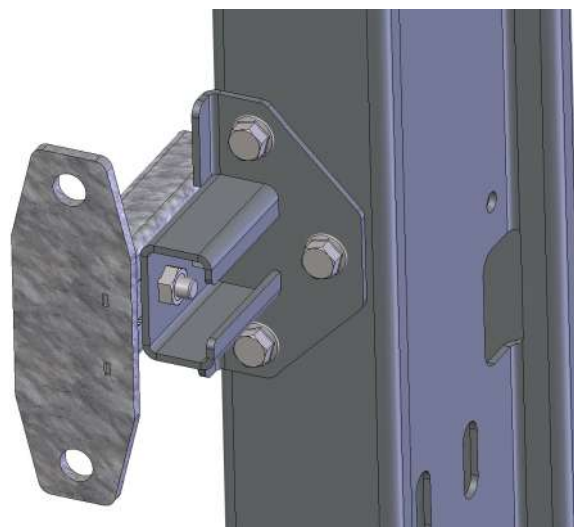

\* when the project foresees the lift fixation with the encircling reinforcing brackets, then the rails must be temporarily secured during assembly, and the lift shaft must be strengthened with encircling elements after the shaft is assembled. See the section 9 for how to fix with the surrounding reinforcing brackets.

8 Diagonal bars (if any) are fixed with cross beams, and at the intersection point with each other, with pins as shown in the figures. Arrange so that they touch each other with the even sides. Secure connections with washers and splints.



9 After the rails are assembled, at the top insert the upper axle assembly and fix with the four hex flange bolts M8x20 and nuts M20, and two hex flange bolts M14x45 with nuts M14 at each side. The top frame is fixed at the same time with the upper screws.

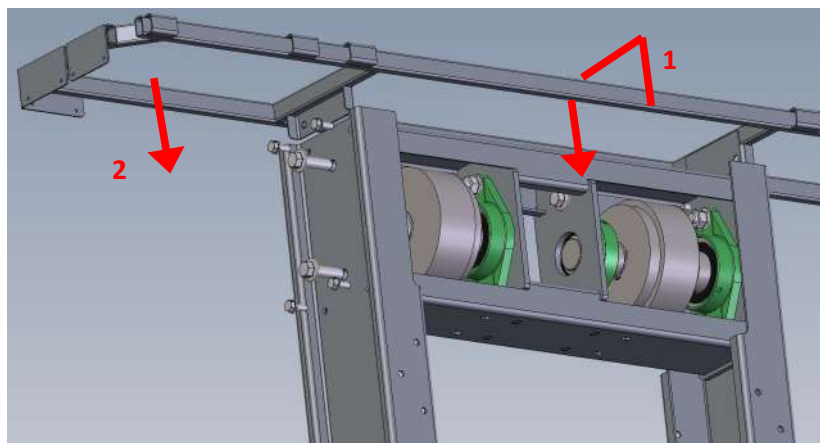

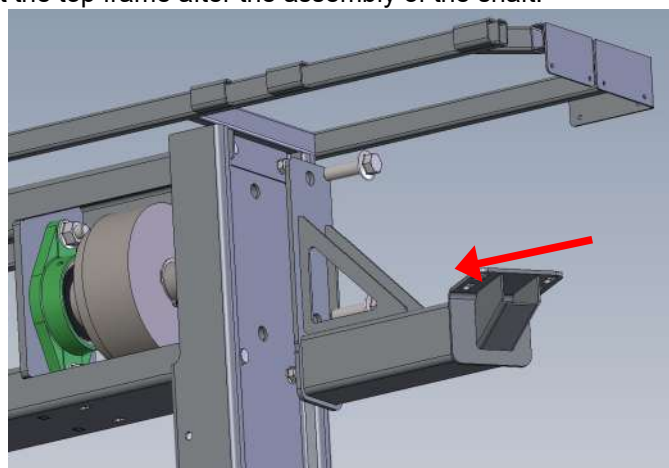

10 On the right side, fix the overspeed mechanism console. It is allowed to install the top frame and immediately tighten with the upper axle module, either later, after completing the assembly of the entire lift shaft, unscrewing the bolts, placing the top frame and retightening the bolts. If so, make sure that it will be possible to put the top frame after the assembly of the shaft.

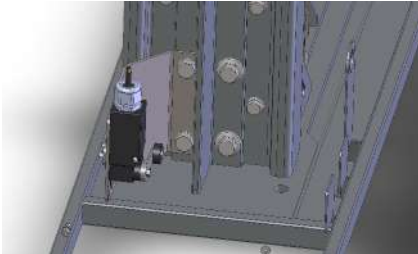
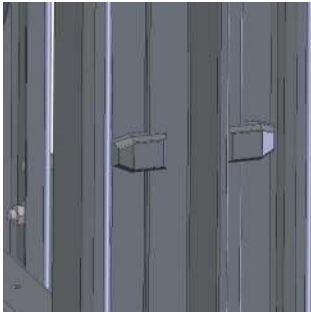
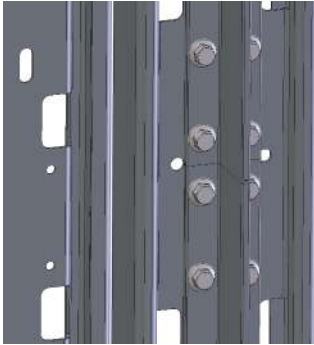
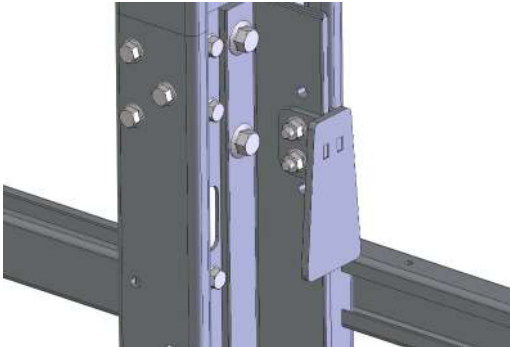

### 3.3. Installation of emergency guide rail

Step	Job description
1	<p>On the outside to the rails attach and fix the T-shaped lift guide rail. At the bottom for both rails attach the bottom limit position sensor brackets with the sensor and fix with bolts M12X30 and flanged nuts.</p> 
2	<p>At an intermediate positions, fix the rails is with cams and nuts M12.</p> 
3	<p>Rails are connected by aligning the notches on the rails and by fixing with M12x30 bolts with nuts to the main guide rails.</p> 
4	<p>At the top end position, the rail is fixed with 4 flange bolts, analogously to the lower one.</p>
5	<p>The last element of the rail has the pre-drilled holes for fixing of the mechanical stop. Attach the brakes to both of rails. Use bolts M8x35 with nuts.</p> 

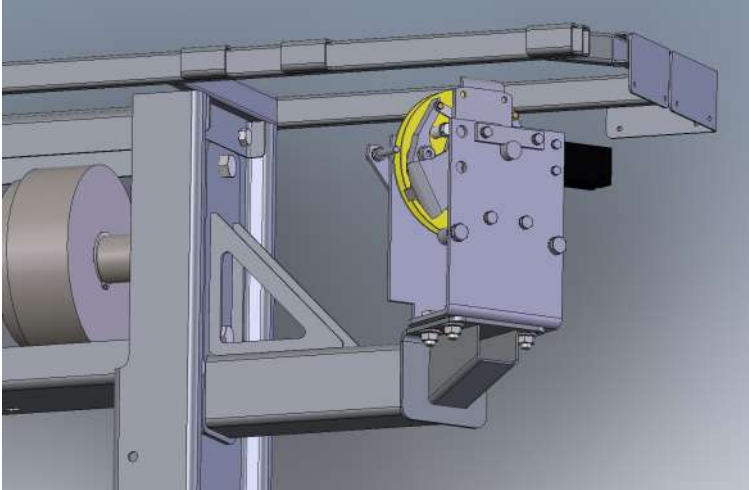
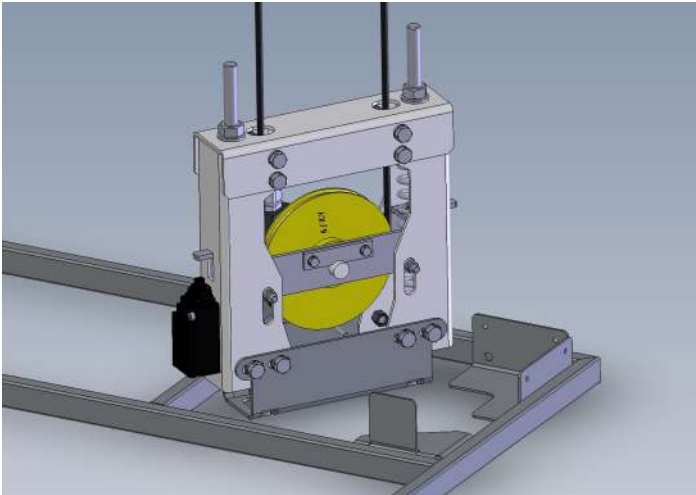
### 3.4. Over speed governor

Step	Job description
1	<p>Install the upper part of over speed governor. Use four bolts M8x20 with nuts.</p> 
2	<p>Pass the rope through the upper and lower over-speed governor pulleys.</p>
3	<p>The lower part is attached to the bracket, which in turn will be attached to the base with an anchor. It is necessary to adjust the position of the lower part so that the rope falls freely and nothing interferes with it. Both the upper and lower elements have adjustment options. If necessary, adjust the parts of the mechanism and fasten. Fix the overspeed governor lower part to the bracket with 8 screws M8x20 and nuts.</p> 
4	<p>Governor rope is tensioned only after the platform is installed, because the ends of the rope are fixed to the brake that is on the platform, so the following works of emergency braking and over speed mechanism installation are completed after the platform is installed.</p>
<p></p>	<p>Compact tensioning pulley provides the governor's rope with the tension required.</p> <p>Points to be taken into account:</p> <ol style="list-style-type: none"> <li>1. Before installation read the instruction manual of tensioning pulley;</li> <li>2. Provided tensioning pulley is designed to be used with Quasar over speed governors;</li> </ol>

3. The following ropes can be used:
- Gustav Wolf: PAWO819W → 6,5 mm;
  - Pfeifer Drako: Drako 250 T → 6 mm;
  - Pfeifer Drako: Drako 250 T → 6 mm.

**Installation of the governor rope:**

The ropes have a stripe painted along the length to check if there are no residual knicks or misalignments in the rope after assembly.

Insert the governor's rope onto the tensioning pulley.

Turn the lower guard for easier rope installation.

Insert the free end of one of ropes branches into the holes on the upper bracket. Pass the rope's end between the pulleys groove and the release-prevention device, surrounding the pulley continuing up to the release-prevention device and going out at the hole opposite the one it was inserted.

Place the lower guard in its initial position and refit the bolt and tighten.

**Rope tightening:**

Before tightening the rope, please make sure that the cable-clips are correctly assembled.



Emergency brake lever

- 5 To tighten the rope, unthread the spring-compressing nuts. It is recommended to unthread both nuts almost at the same time. The both rope-tensing springs become release, the pulley uniformly lowers and the rope becomes tightened. Unthread the nuts until the springs are completely released.
- If after complete unthreading the nuts it is detected that the de-tensioning contact actuator is in the contact or about to contact the de-tensioning contact, release the rope from the cable clips, and pre-tighten the free end of the rope again.
- Due to normal elongation unentightening may occur.
- To detect rope unentightening or even breakage, tensioning pulley incorporates an electrical contact. The contact shall be connected to the lift's safety circuit.

### 3.5. Installation of a pit prop

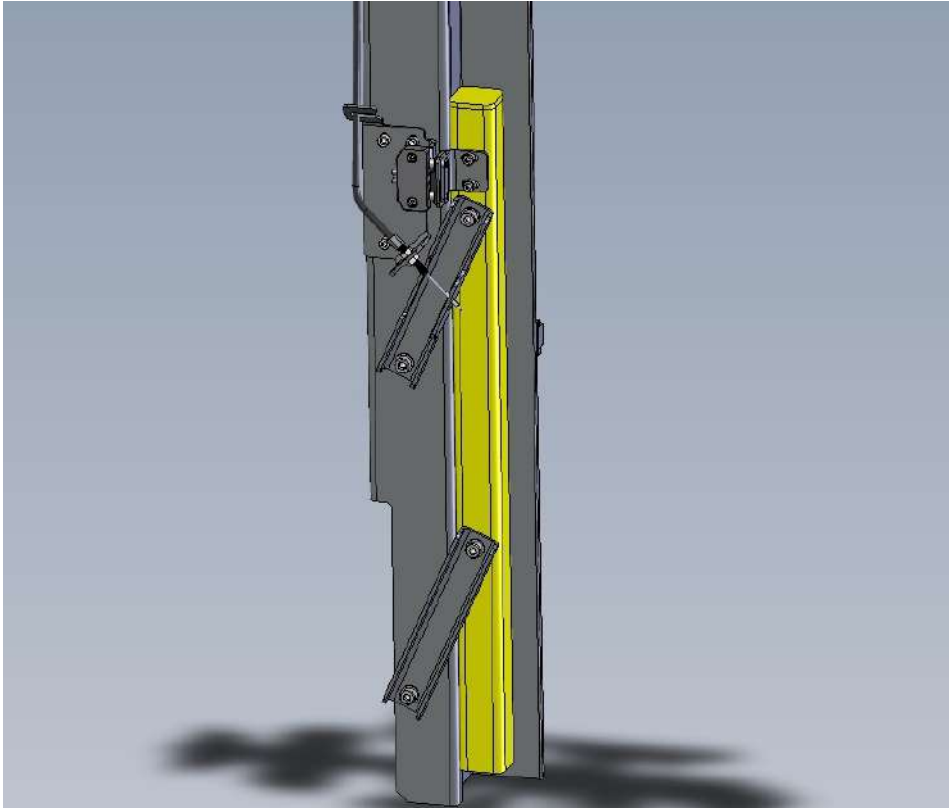
Step	Job description
1	Attach the pit prop to the right side guide rails and the bottom frame.
2	<p>Attach the pit prop activation mechanism corresponding to pit prop's contact pins. Align it on the guide rail so that the contacts would freely go out of suspension and make sure there be no obstacles for prop's rope for engegement of the pit prop. Pass the sensor's cable and the rope to the electric compartment. Use plastic zip brackets for cable addaptation. Connect the cable to the controller. Adjust the tension of rope and test the performance. For fixing use socket head cap screws M8x20 with plain washers A 8.4. Use screws M6x10 to fasten the contact details.</p> 

### 3.6. Position sensors

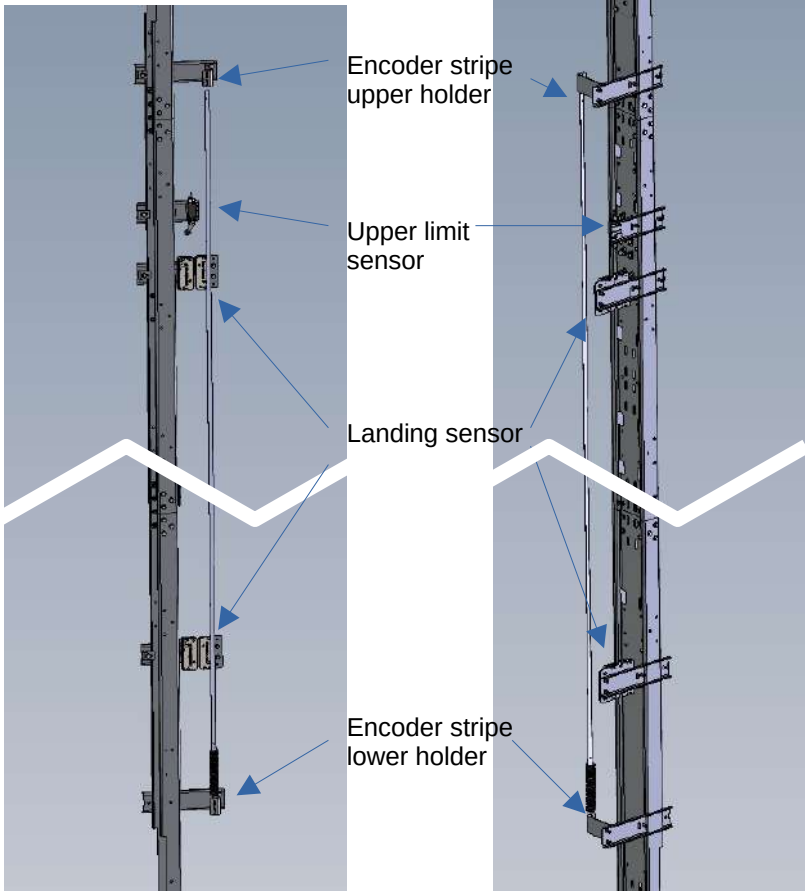
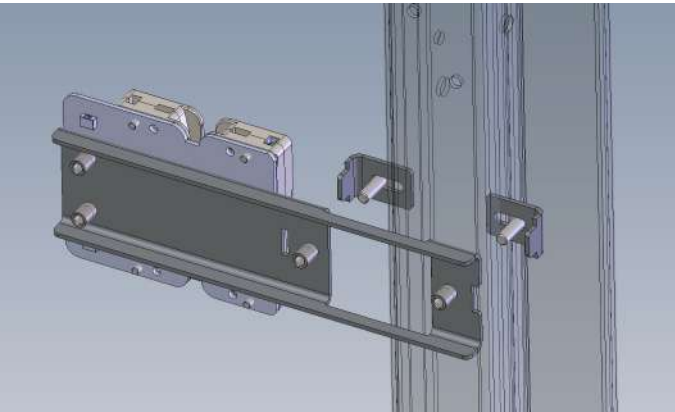
Step	Job description
1	On the right side guide rail install platform position sensors along with an Encoder tape holders.
2	<p>The picture shows the sensors and the correct sequence of their arrangement.</p>  <p style="text-align: center;">Front view <span style="margin-left: 200px;">Rear view</span></p>
4	<p>The sensors' brackets are fixed to the rail as shown in the picture. Use bolts M8x16.</p> 
5	At the bottom, along to the position sensors, the decoder tape bracket, frequency converter box brackets and the inverter brackets are installed (the last on the left hand side).

### 3.7. Platform

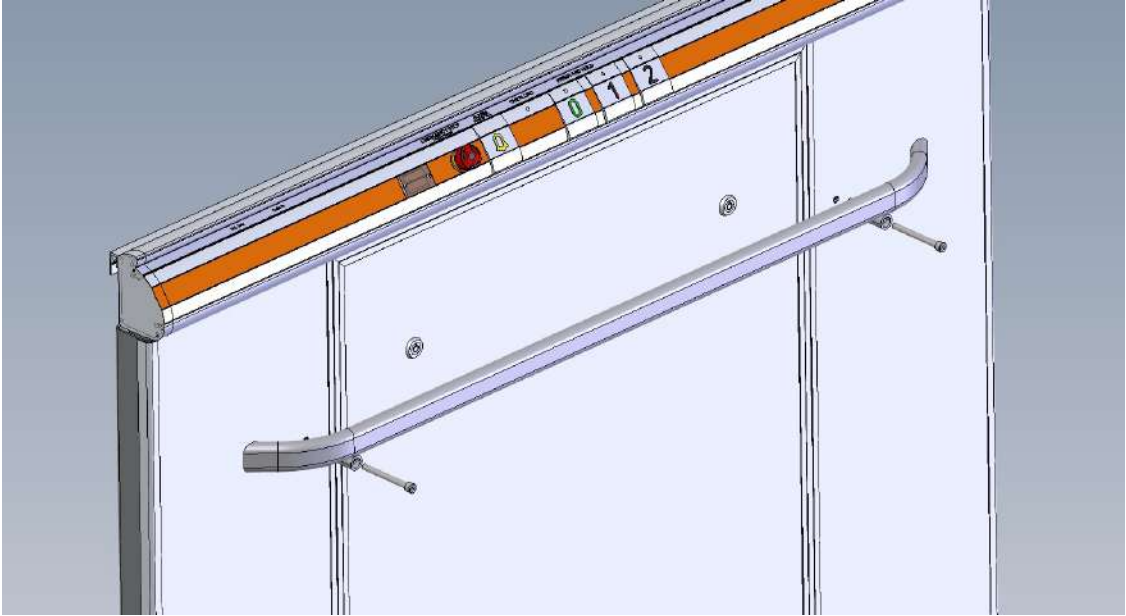
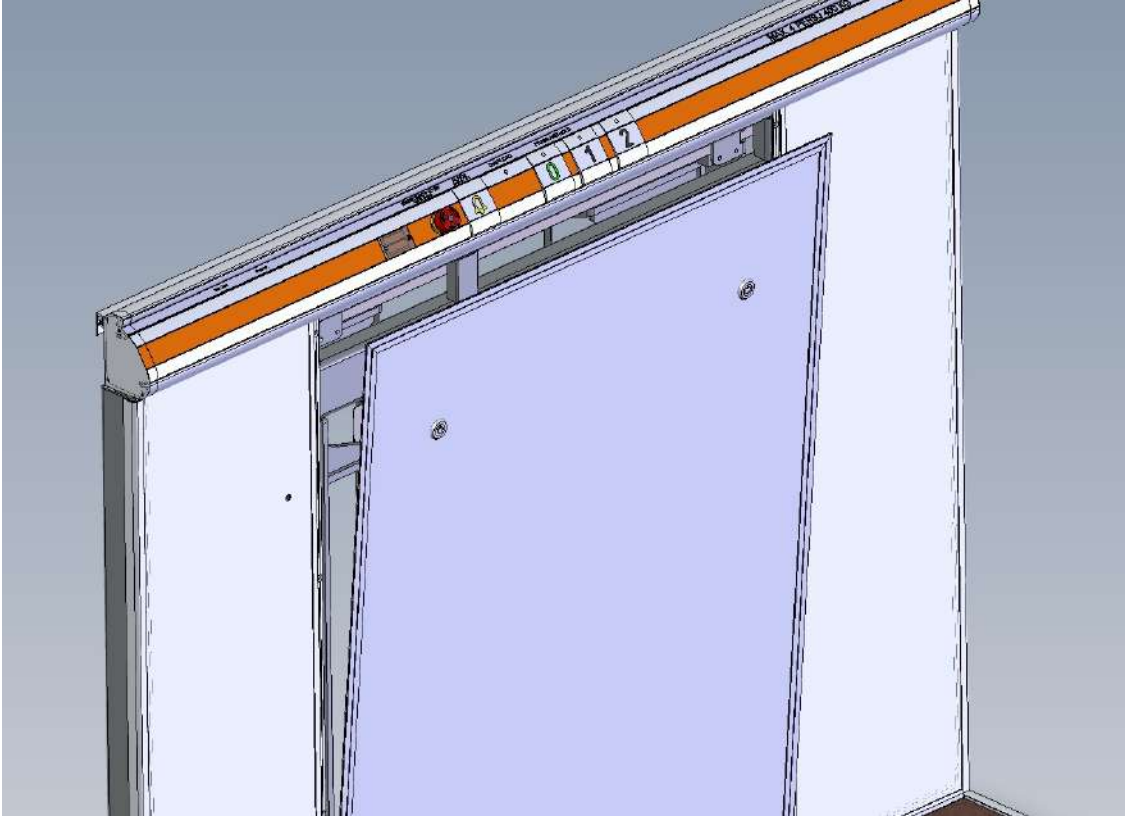
Step	Job description
①	Cover the platform pad in order not to damage the surface
1	<p>Platform is delivered assembled with a control panel. In order to install a platform in the lift shaft, it is necessary to remove the panels of the platform. First remove the handle by unscrewing the screws below the handle.</p> 
2	<p>With the help of a special key, unlock the locks and remove the central part.</p> 

3

Remove the sides

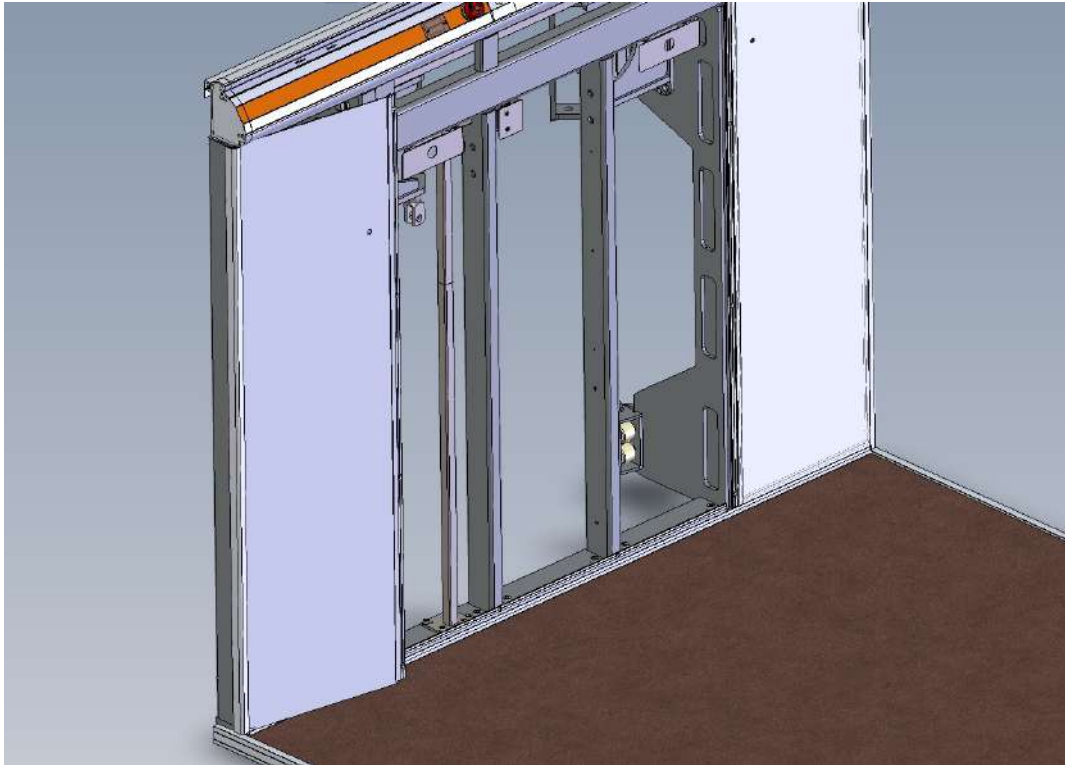

4

In the case of a high console, the handle and all shields must also be removed before installing the platform.

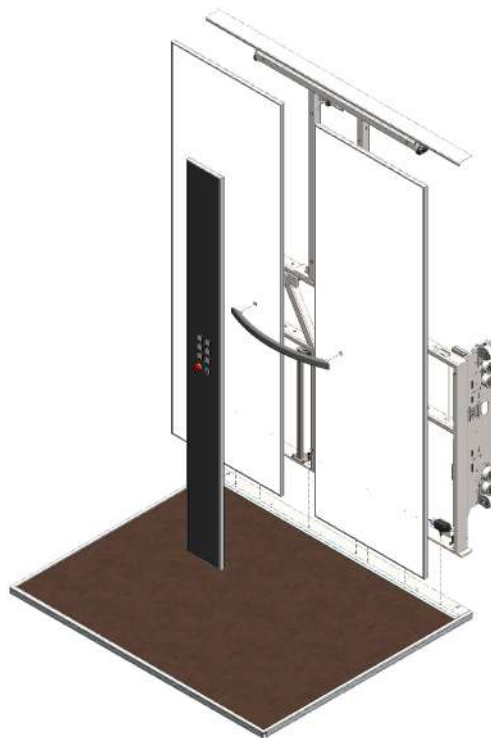

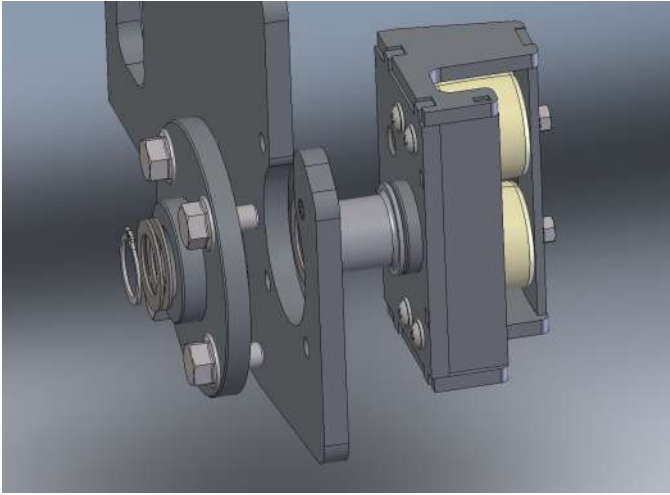
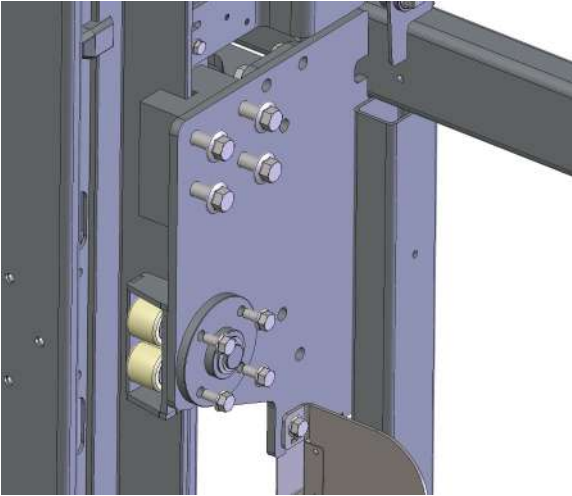
5	<p>Remove the top and bottom roller units untightening 4 screws M8x16.</p> 
6	<p>At the top, remove the emergency brake unscrewing the screws M12x25 - 4 units.</p> 
7.	<p>Place the platform in the elevator shaft and reattach the roller assemblies and emergency braking devices.</p>

### 3.8. Installation of belts

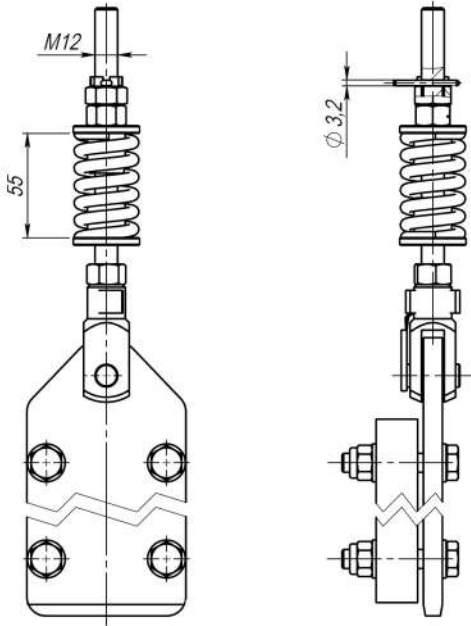
Step	Job description
1	<p>The method of attaching the belts to the platform is shown in the picture.                      Pre-hook the ends of the belt with the fixing clamps in advance.                      If the belts appear to be too loose during fastening, the fastening grooves should be moved to shorten the length of the belt.</p> 
2	<p>Route the belts and fix with the platform the upper end first.                      Pretighten the belt by tightening the nut to the length of 55 mm.</p> 

3

Secure connection with double nuts and a cotter pin as it is shown in figure.  
Drill a hole through the stud in order to pass the cotter pin.



①

**The attachment of the belts to the platform must be secured with double nuts and a cotter pin.**

### 3.9. Encoder stripe installation

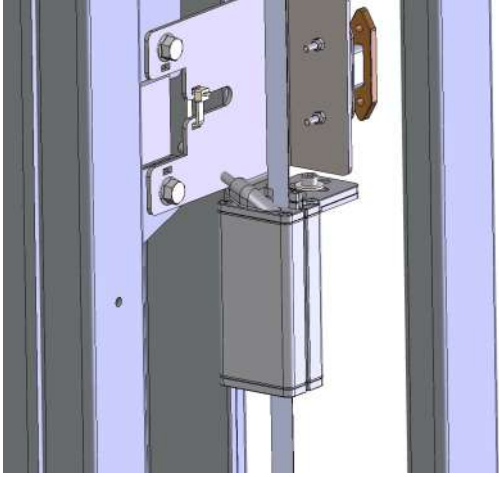
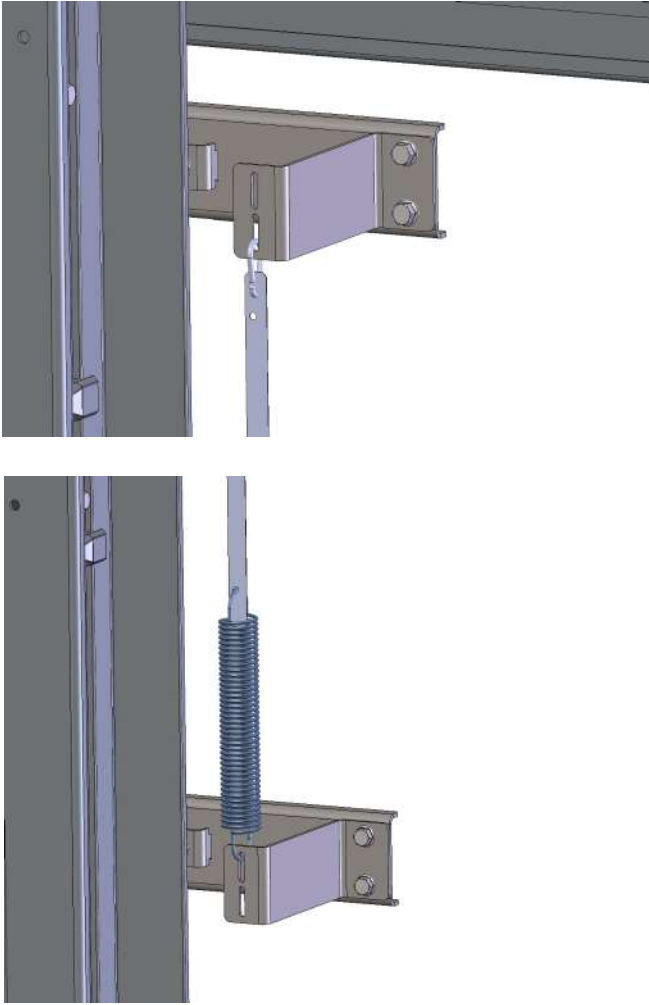
Step	Job description
1	The encoder is affixed to the platform frame.
2	<p data-bbox="260 371 911 405">Pass an encoder stripe through the encoder's housing.</p> 
3	<p data-bbox="260 931 1358 1003">Attach the encoder tape. It must have a tensile spring at the bottom. Adjust the encoder tape tension by changing the positions of the encoder band brackets.</p> 

### 3.10. Installation of control system elements

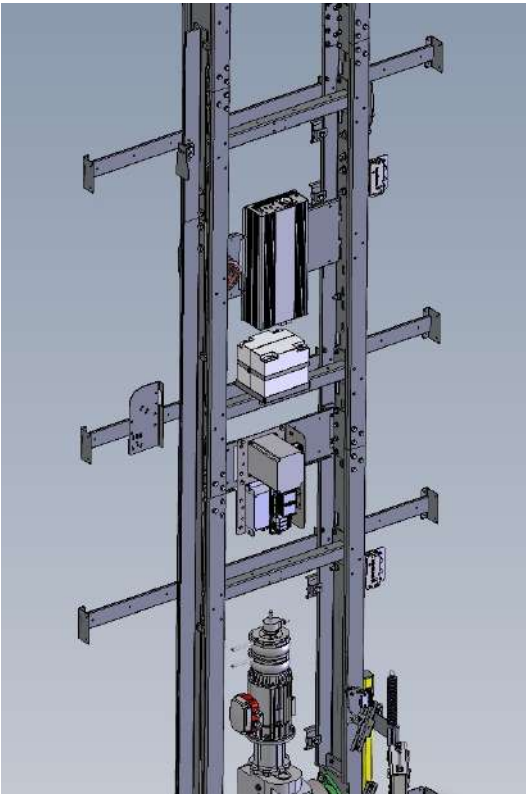
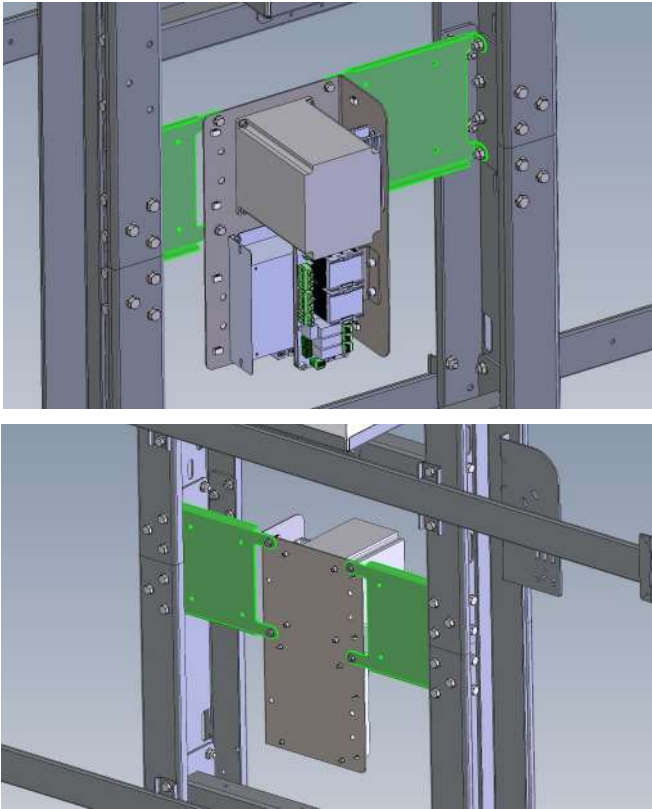
Step	Job description
1	<p data-bbox="260 286 1137 315">Install lift control and power supply devices in the space between the rails.</p> 
2	<p data-bbox="260 1182 1201 1211">The electronic control unit is installed at the first rail joint using mounting plates.</p> 

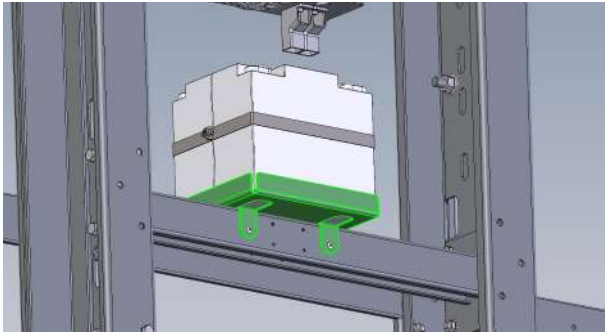
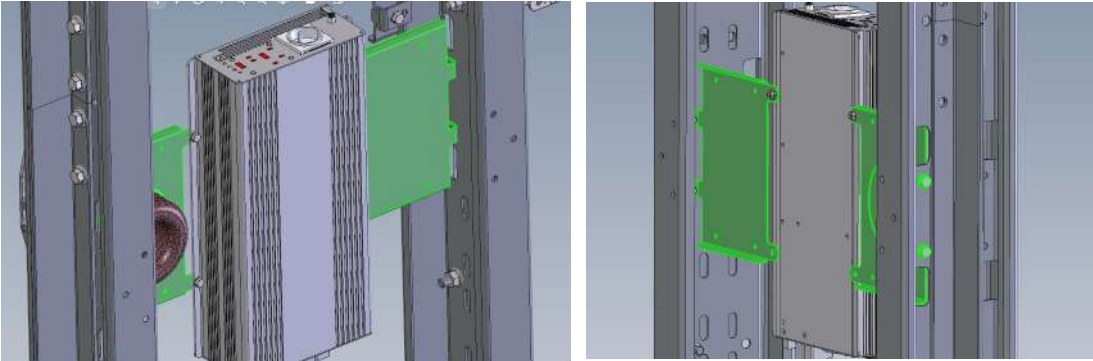
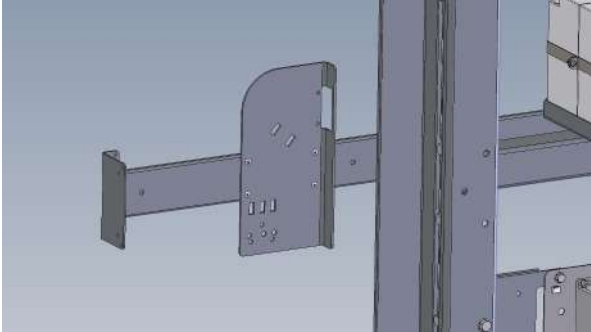
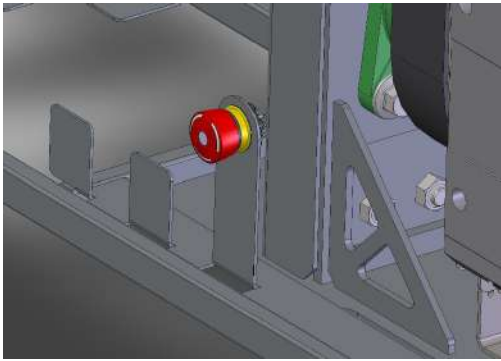
<p>3</p>	<p>The battery block site is fixed with rivets to the crossbar.</p> 
<p>4</p>	<p>The voltage inverter is fixed via additional mounting elements.</p> 
<p>5</p>	<p>Fasten the cable track guide with rivets. The position is indicated in the lift drawings.</p> 
<p>6</p>	<p>Fix an emergency switch to the bottom frame's bent console. Pass the cable troughout the door's compartment same way as the pit prop's cable. Connect Emergency swich cable to dedicated connection on the contreller board.</p> 

## 4. WIRING AND CABLE MANAGEMENT

Please refer to the lift original circuit diagram when performing wiring. Images bellow indicate interconnections of all controller boards and electrical components.

### Connections between all PCBs

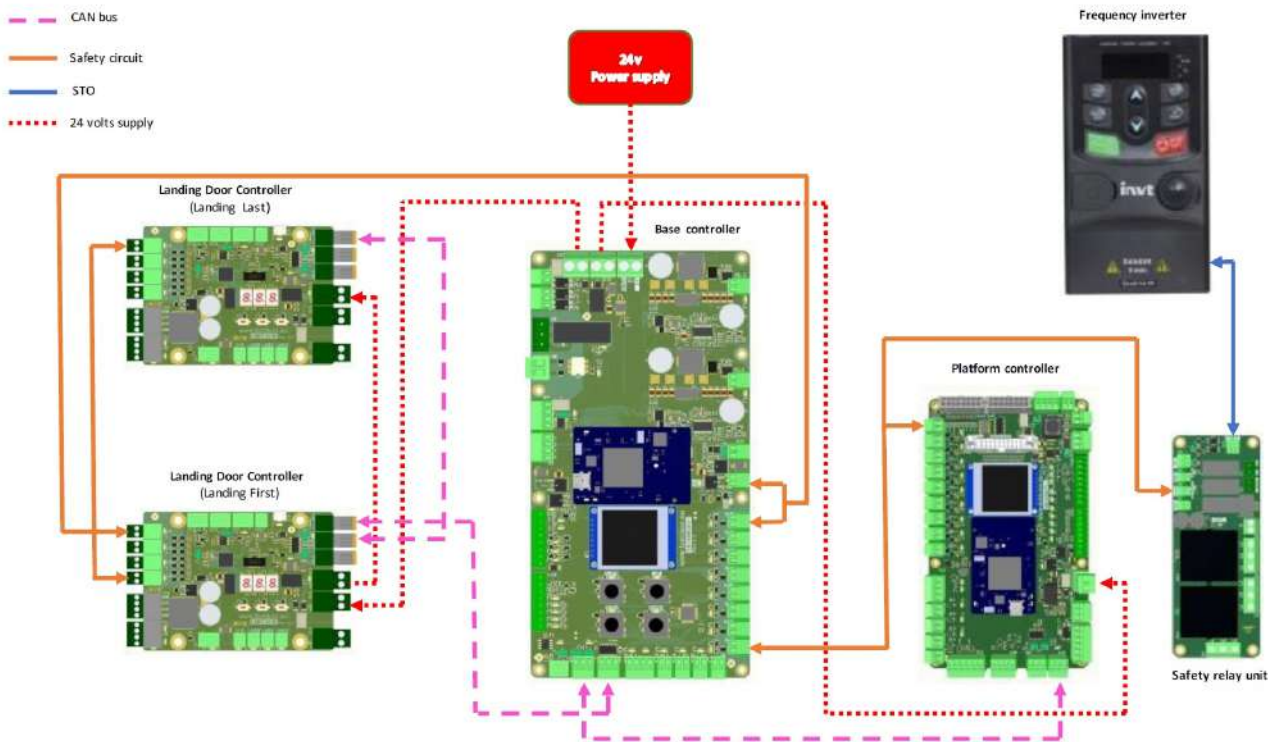

### Base Controller

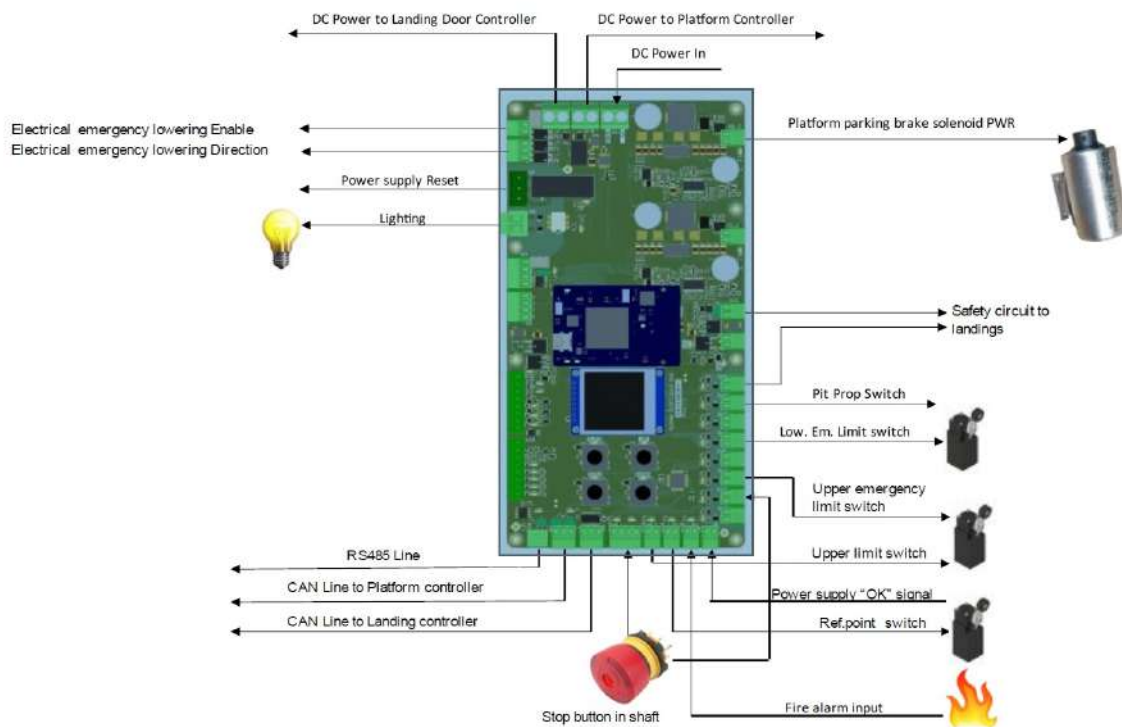

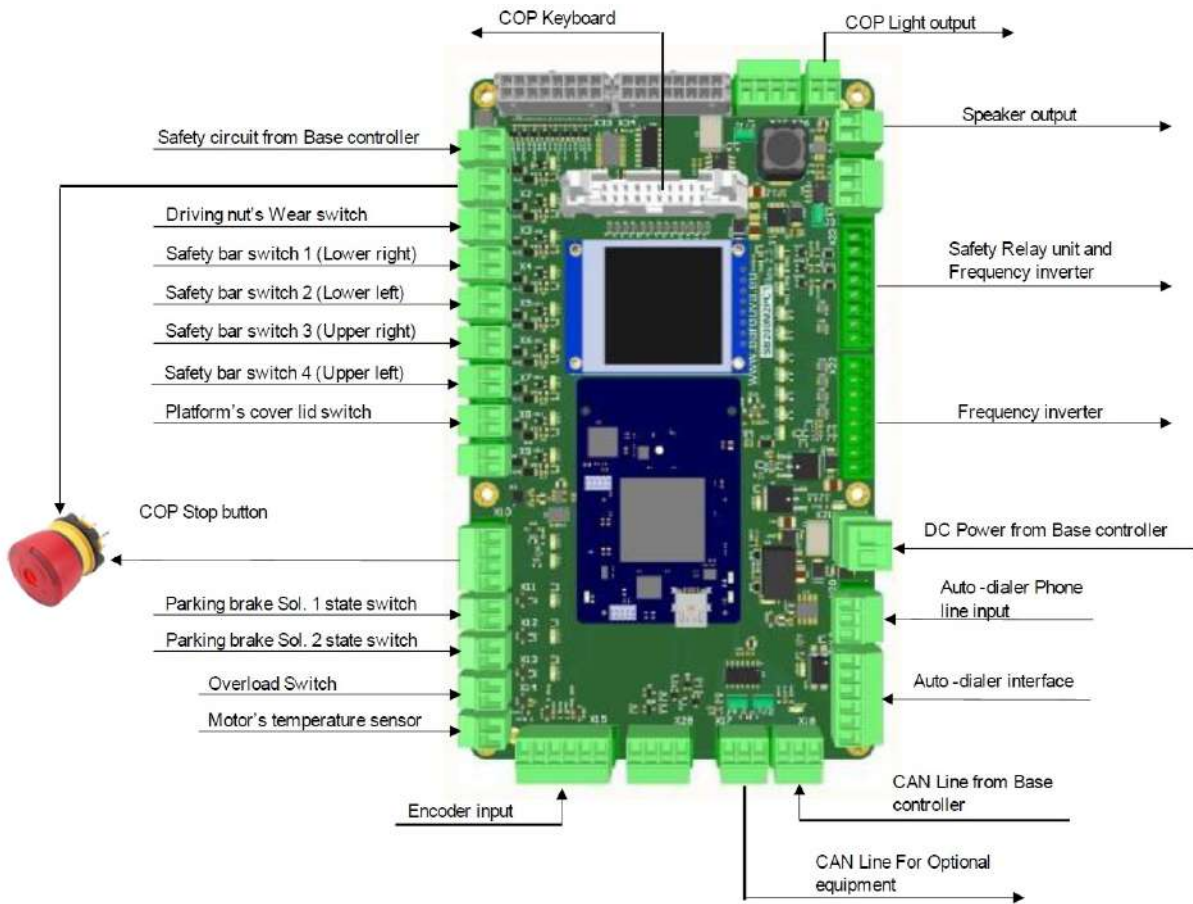

## Safety relay unit

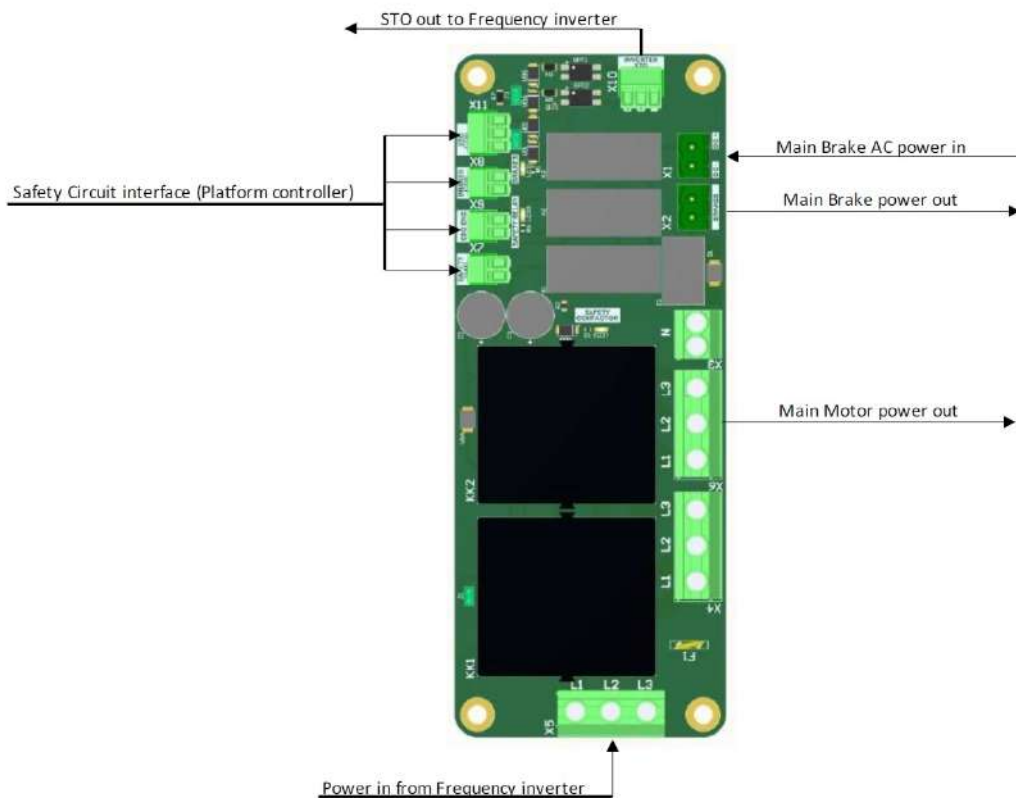

LANDING CONTROLLER

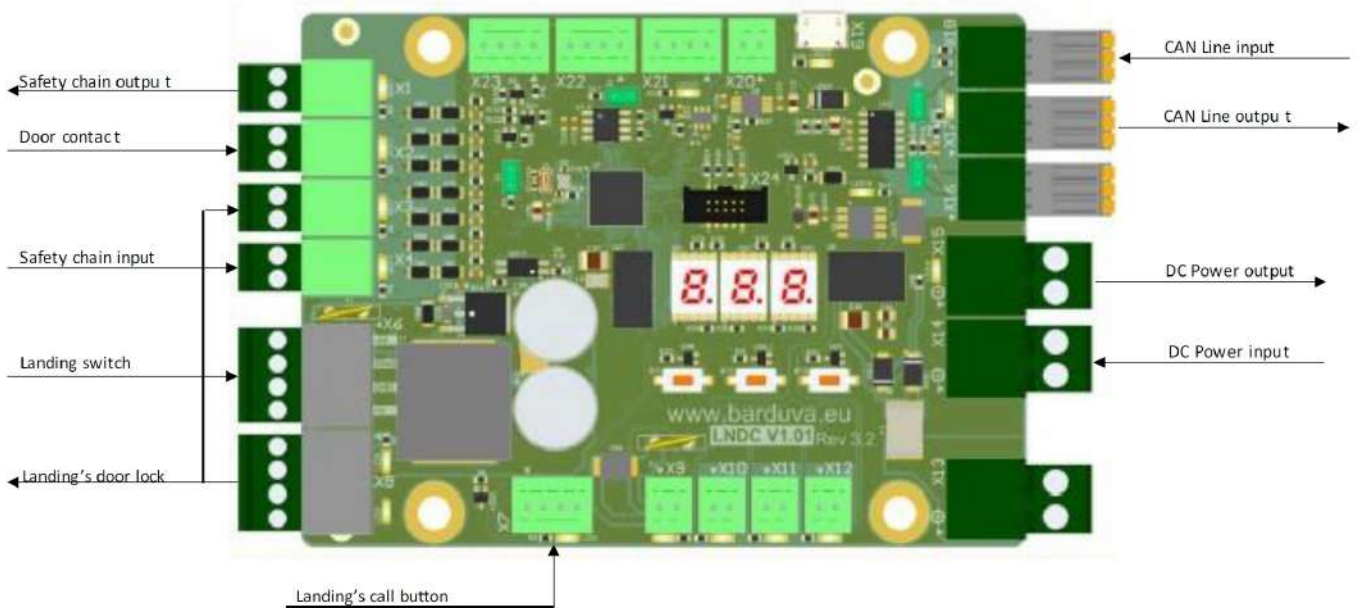

Most of the components come already pre wired, at final assembly stage only those connections after installing components must be done:

- Trailing cable connections;
- Pit prop and bottom switch;
- Backup batteries;
- Phone and fire alarm connection line (if any);
- Landing and override sensors ramps;
- Door controllers connection cable;
- Ceiling lighting cable;

Doors' cables and ceiling lighting cables are laid in the guide rails duct and after fitting them the duct will be closed by clip on lid.

The lid have to be pressed towards the guide rail till you hears a click, if required use a soft rubber mallet to hammer a bit.

Components of floor control system are located in top part of door frame. Each floor has its own control system located in same area.

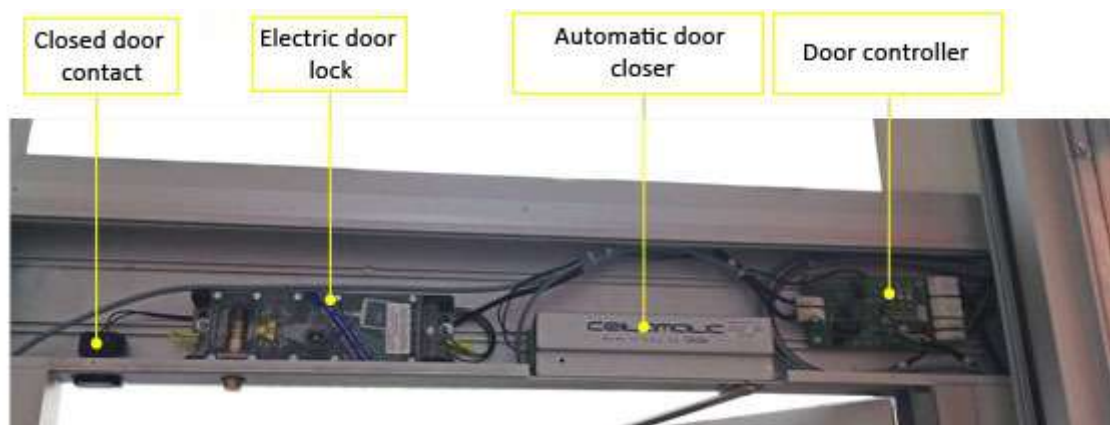

## 5. LIFT SHAFT AND DOORS

### 5.1. Lift shaft assembly

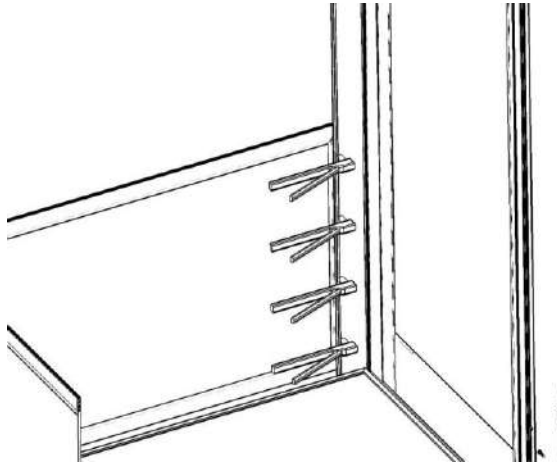
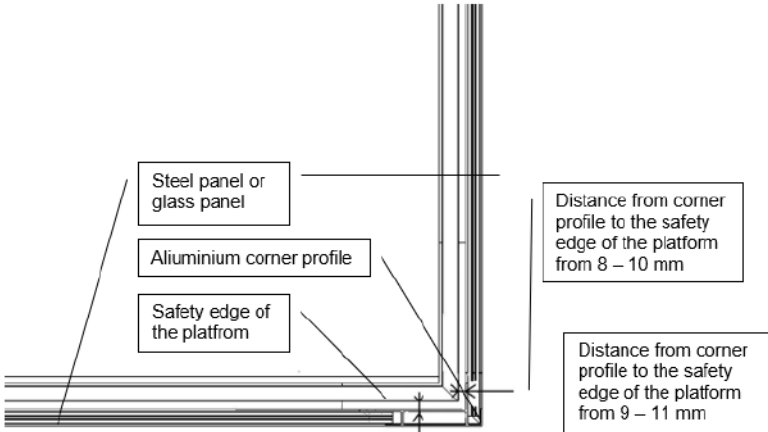
Step	Job description
1	<p>On the base frame put in the 50 mm height aluminium profiles around the lift well. Begin assemble from the side opposite to the bottom landing door. Make sure to left 3 mm distances between the bottom profiles and later between sandwich panels and corner profile bed. The bottom profile and the sandwich panels shall be riveted to the corner profiles with 4 mm rivets. Apply at least 4 pics of rivets for a single panel.</p> 
2	<p>Use 3,2 mm diamter rivets when fixing the panels and doors with the corner profiles from inside of the lift well. Corner profile has 2 grooves going along the profile length. Apply the rivets in to the groove that is closer to the edge of the profile. With the every next panel, make sure to maintain the recomended distances from the platforms safety edges to the wals of a well.</p> 

## 5.2. Doors

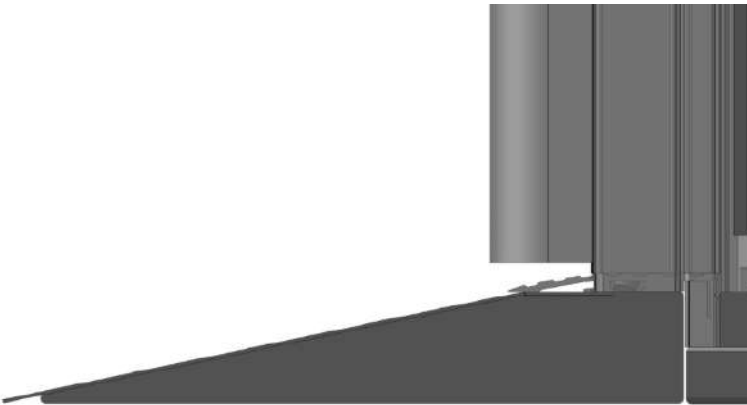
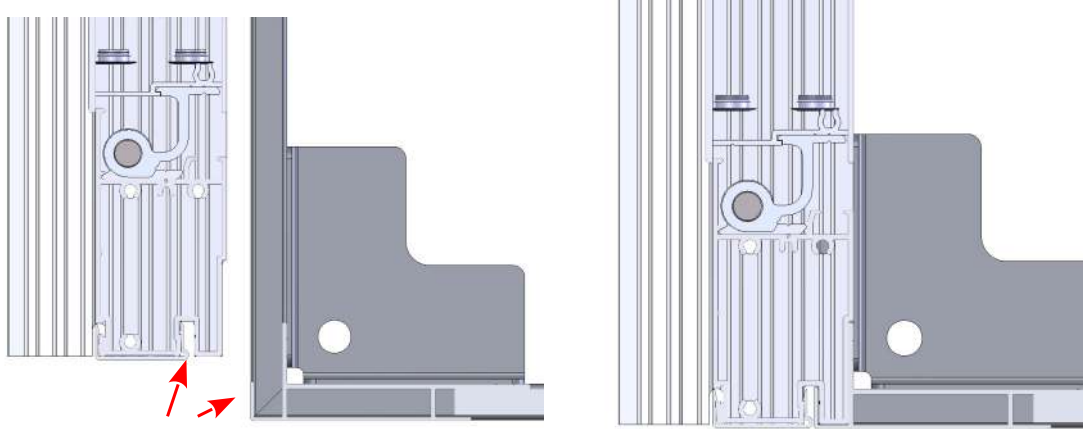
Step	Job description
1	To proceed with installation of the doors, at least one of the corner profiles must be installed prior the door installation. For the sides A and C it must be the machine room corner. If the door is on D side, the corner profile on the hinge side of the door must be installed first. If the door is being installed in the building wall aperture, the opening must be at least 40 mm wider than the door overall width. Please note, that from the outside there would be enough room left for emergency door release key, i.e. 20-30 mm spare distance.
2	The door frame lower profile shall fully rest on the landing floor, either on the ramp if ordered for installation in an absence of a pit. <div style="text-align: center;">  </div>
3	If the door is on sides A or C remove the lid from the wide side profile (electric compartment lid) before beginning the installation.
4	Check, if the gap in the door frame is in level with the aluminium corner profile.
5	Push or pull the door to the side where gap of the door frame is, until it would fit with corner profile; <div style="text-align: center;">  </div>
6	Adjust the doors to the level
7	Drill Ø5 mm holes from outside of the shaft through the guide rail in the pre-prepared places on the

doors

DIN 7976 ST6.3x13

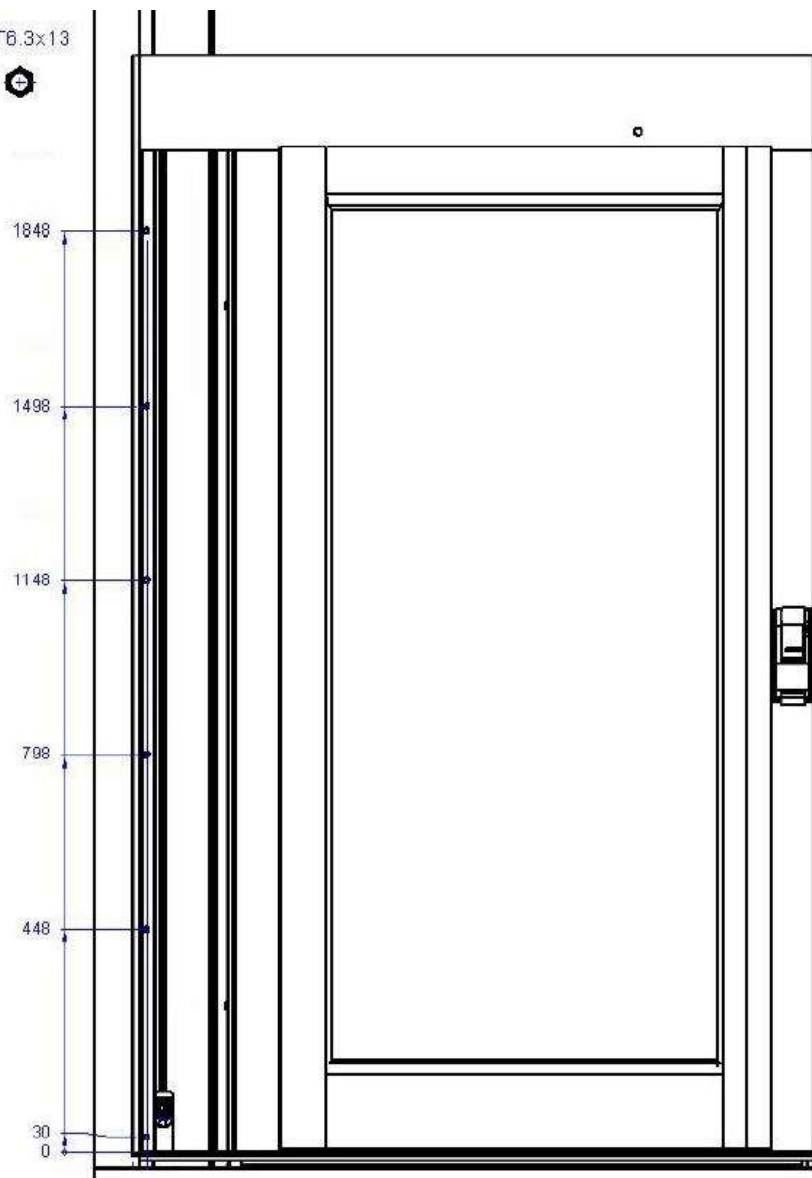

*Recommendation:* drill for one hole at top and bottom positions first and tighten. Check the level of doors and drill and tighten the rest of the holes.

8

After placing the door into place, make sure that the corner profile is perfectly in the groove of the door. Fix the door to the guide/rail at the pre drilled holes.

### 5.2.1. Planks under and above the doors

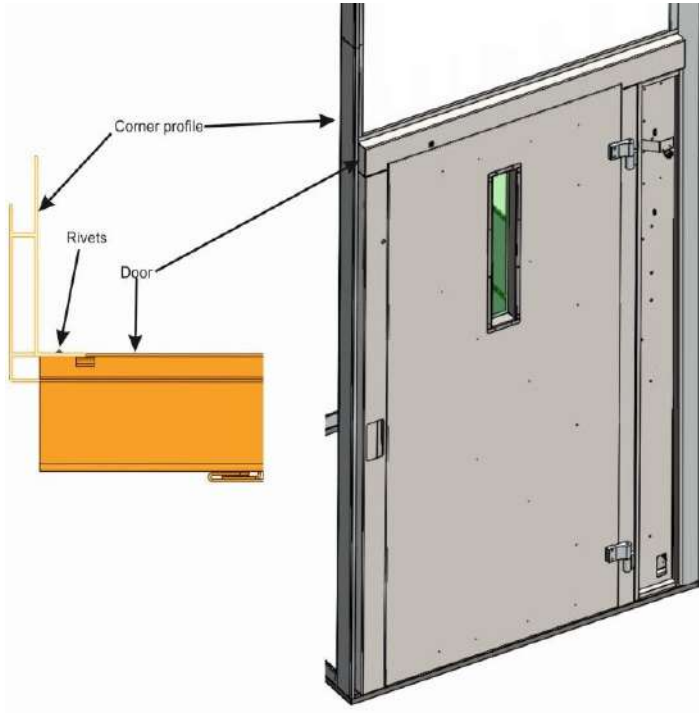
Step	Job description
1	<p>Fit the cover planks under and over the doors and rivet it with Ø3.2x8 rivets in three places;</p> 



### 5.2.2. Placing the rescue instructions

Step	Job description
1	Place the emergency rescue instructions in the pocket inside of the electrical compartment cover.

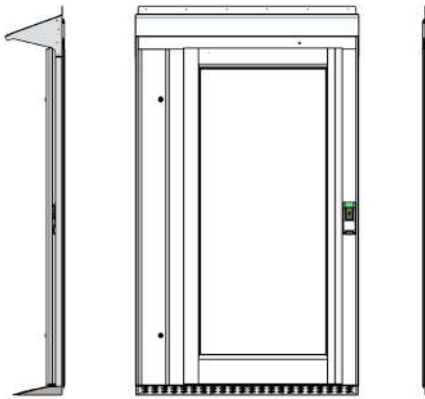
### 5.2.3 Installation of door canopy (if any)

Step	Job description
1	<p>In case of outdoor lift, all doors exposed to outside environment must have a canopy. The canopy must be attached using silicone sealant. Before applying the sealant clean the surface of canopy and lift, degrease with isopropyl alcohol. Do not use acetone since it can damage the surfaces. Canopy has pre drilled holes for 3,2 mm diameter rivets. Drill corresponding holes into the door structure and fix with the rivets.</p> 

### 5.3. Installation of self rescue rope

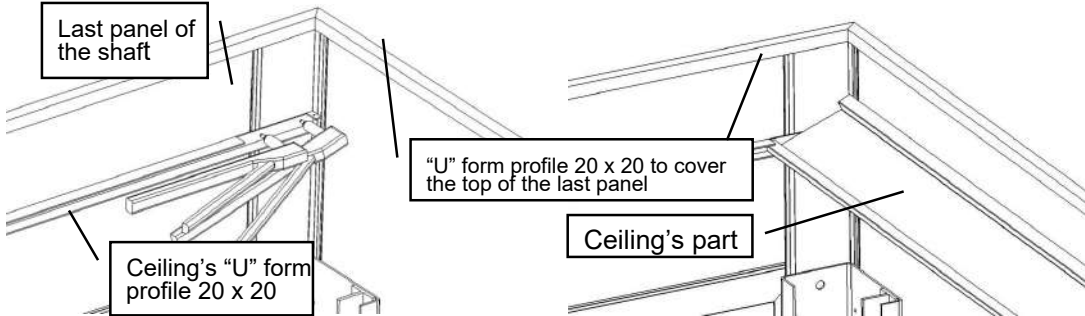
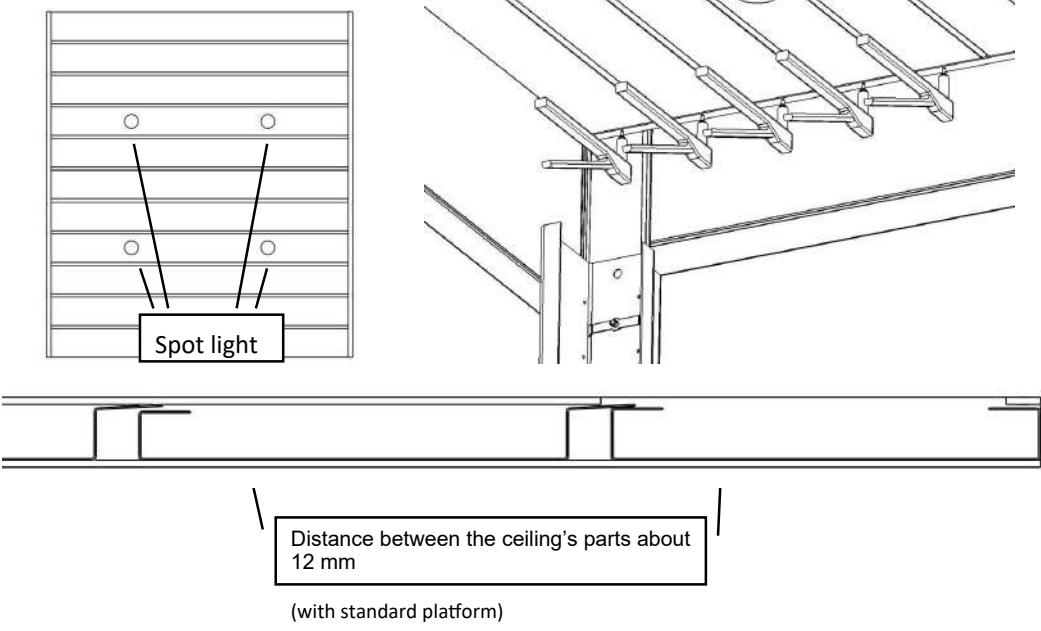

Step	Job description
1	<p>The lower door has to have installed a self-release rope. After installing the lower door, pull out the rope and place it on the floor of the elevator shaft. Check if the rope is attached to the door lock mechanism.</p>  <p>The image shows the internal mechanism of the elevator door lock. A black motorized unit is mounted on a metal plate. A white self-release rope is connected to the mechanism. The motor unit has a label that reads 'SIE200 DMCV-4 80 RPM'. To the right, there is a metal component with 'Hydromme LRCE' and 'gudromme s.r.l.' printed on it. The background shows some wiring and a handwritten number '01243' on the metal housing.</p>
2	<p>View of the self release rope on the floor.</p>  <p>The image shows the floor of the elevator shaft. A black self-release rope is lying on the floor. A red arrow points to the rope. The rope is connected to the door lock mechanism. The floor is made of concrete. There is a small white label on the floor that reads '25 x 22'.</p>

## 5.4. Assembly of a ceiling

Step	Job description
1	Before starting the ceiling assembly fix the „U“ form profile 20 x 20 on the last panel;
2	Fit the ceiling holding „U“ form profile 20 x 20 on the long side of the shaft and rivet it with Ø 3.2x8 rivets;
3	Make the same on the opposite side;
4	Fit in the ceiling parts;
	 <p>Diagram illustrating the installation of the ceiling structure. It shows the 'Last panel of the shaft' and the 'Ceiling's „U“ form profile 20 x 20' being attached to the shaft. A separate view shows the '„U“ form profile 20 x 20 to cover the top of the last panel' and the 'Ceiling's part' being fitted into the structure.</p>
5	Check that the ceiling parts with pre-fitted lamps would be at the center of the shaft; the configuration of ceiling parts for the standard platform dimensions should be: - 3 blind parts; - 1 part with spot lights; - 3 blind parts; - 1 part with spot lights; - 3 blind parts;
6	The distance between the ceiling parts should be about 13 mm, for standard platform dimensions;
7	Rivet the ceiling's parts at the middle on each side with one rivet of Ø 3.2x8;
8	 <p>Diagram illustrating the final ceiling assembly. It shows a perspective view of the ceiling parts with spot lights. A cross-section view shows the spacing between the ceiling parts, labeled as 'Distance between the ceiling's parts about 12 mm (with standard platform)'. A label 'Spot light' points to the light fixtures.</p>

## 6. ASSEMBLY OF GUARD WALL

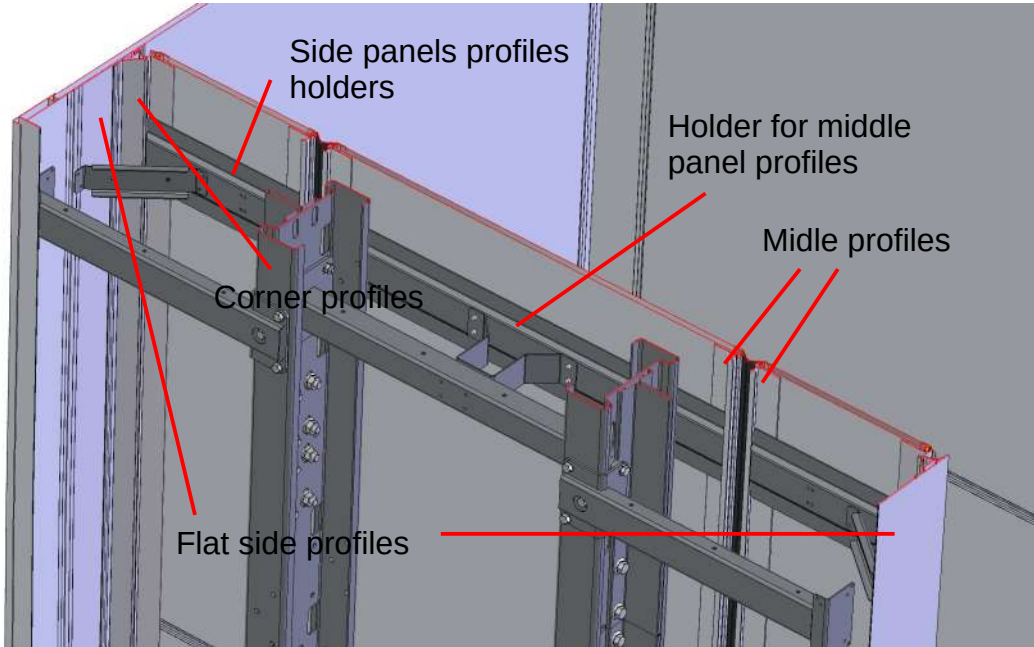
### 6.1. Inner panel wall

Step	Job description
1	The inner wall may be installed only after the assembly of elevator shaft.
2	<p>For that purpose, it is first necessary to install aluminium profiles holding sandwich profiles, the layout of which is shown in the picture.</p> 
3	<p>At the lower and upper frames, the corner and middle profiles of the inner wall are attached to specially prepared clamp elements. Fastened with rivets.</p> 
4	<p>Between the lower and upper frames, the profiles of the inner walls are fixed through the side and middle brackets (see figure above). The amount and the place of attachment coincide with the crossbars of the rails. The middle element is attached to the crossbar between the rails. The plates are fixed at the ends with aluminium profiles with rivets</p>
5	<p>The side profile holders are additionally fixed with rivets to the flat side profile. The side flat profiles are pressed against the shaft sandwich panels and the end touches the corner profile of the shaft. The flat side profile is not added to the door: it is replaced by the door profile.</p>

6

After inserting the sandwich panels, panels are fixed with press-on strips.

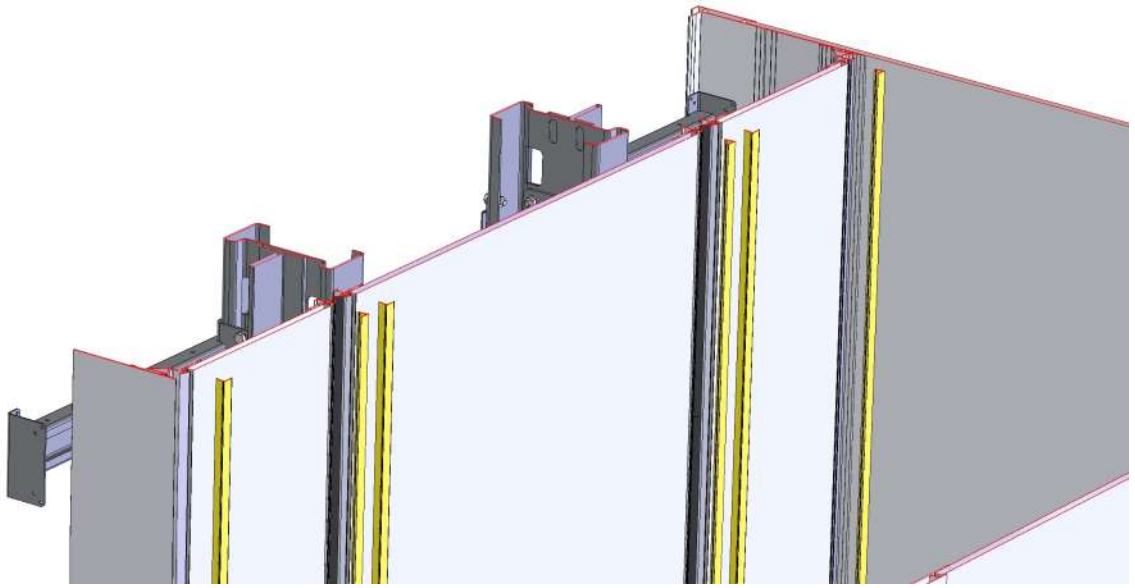

## 7. ASSEMBLY OF A ROOF (OUTDOOR OPTION)

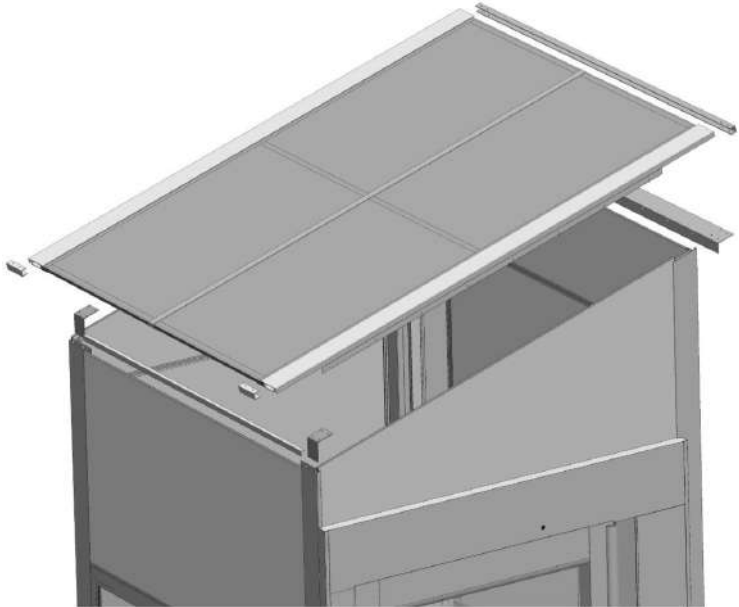
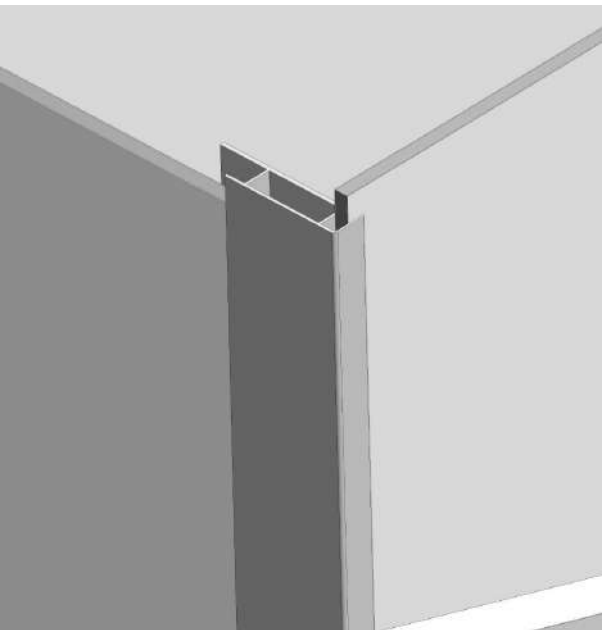
Step	Job description
1	<p>Lifts for outdoor use come with a roof. The layout of a roof is presented in the image.</p> 
<p><b>ⓘ Note: all the elements shall be placed after silicone sealant application.</b></p>	
3	<p>Trim the adjacent sandwich panels to match the angle of the roof. Leave 10 mm excess protruding from corner elements. Panels on the other two sides shall be trimmed 10 mm lower than corner profiles edge.</p> 
4	<p>It is strongly recommended to leave the top sandwich panels without fixing till the roof will be placed in place.</p>

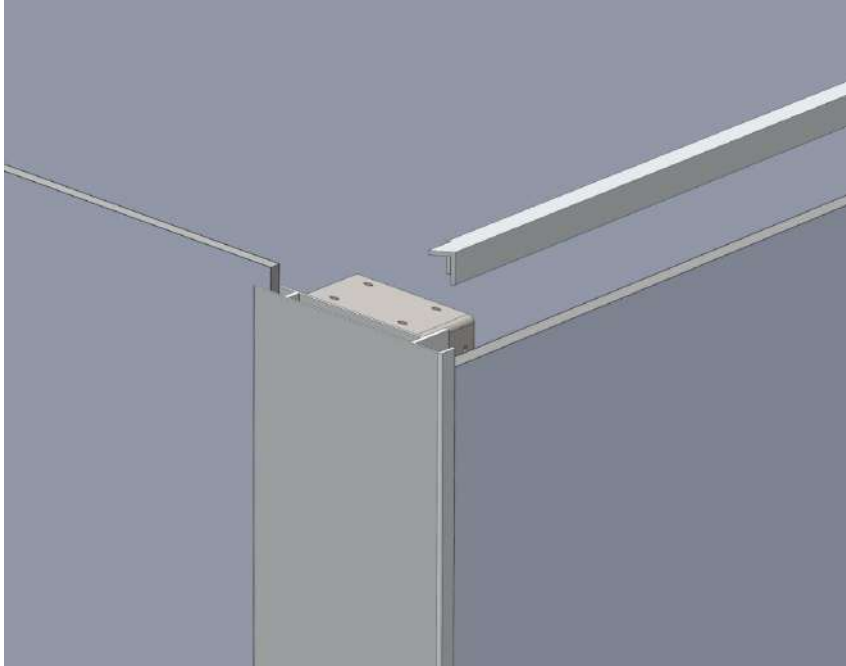
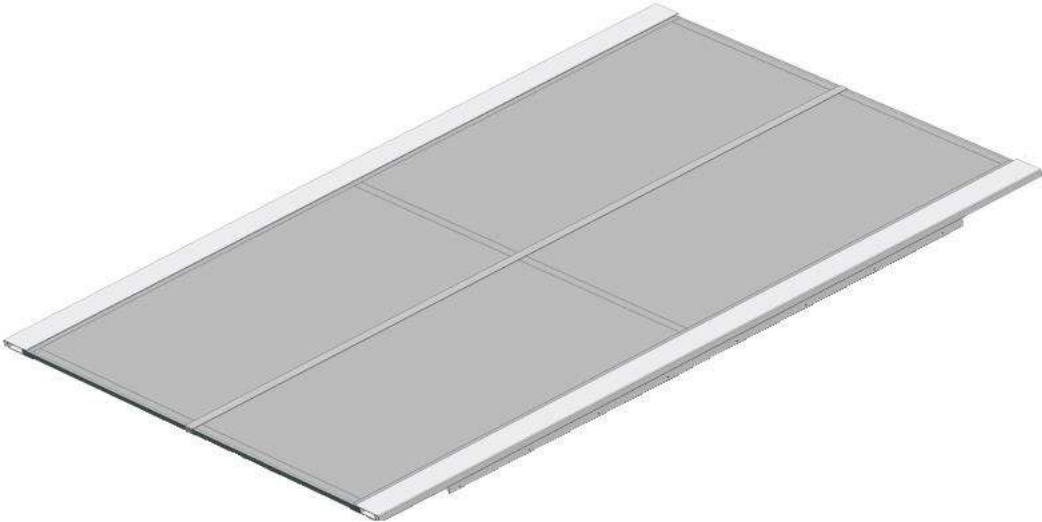
<p>5</p>	<p>Put a layer of silicone sealant inside the gap of profile that must be placed at the lower side of the roof and applied it as shown in the image</p> 
<p>6</p>	<p>Apply side profiles of roof panel to the roof. Put a layer of silicone inside the profile's gap. Secure the profiles to the roof panel utilizing 4 mm diameter rivets. The rivets must be applied from inner side of the shaft along the edge of profile, each 190 mm.</p> 
<p>7</p>	<p>Before placing the roof on the top of the shaft, apply a layer of silicon inside the profile's gap. Put the roof to a place. As soon as it is well aligned and there are no visua gaps, secure the roof to the side sandwich panels from inside utilizing 3,2 mm diameter rivets.</p>
<p>8</p>	<p>Place additional reinforcement brackets in the corners of the lower shaft's side and secure them to the</p>

roof and the shaft utilizing 4 mm diameter rivets.

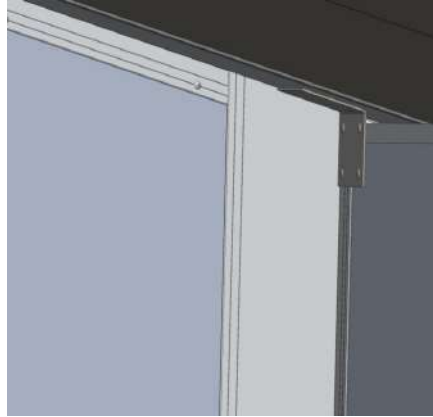

9

Finally apply the longer 20 x20 U profile to the upper edge of the roof.

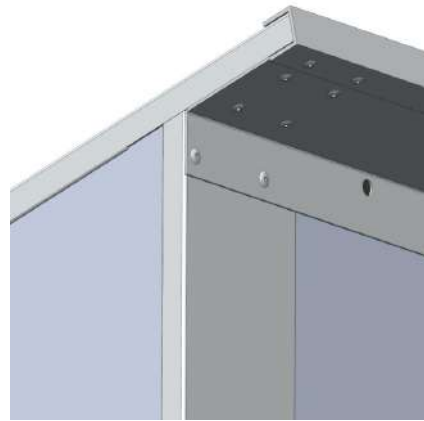

10

Secure the U profile and the roof at both the upper corners utilizing 4 mm diameter rivets. Place two short 20 x20 U profiles in the lower corners of the roof and secure them utilizing 4 mm diameter rivets.



## 8. LANDING PREPARATION FOR USE

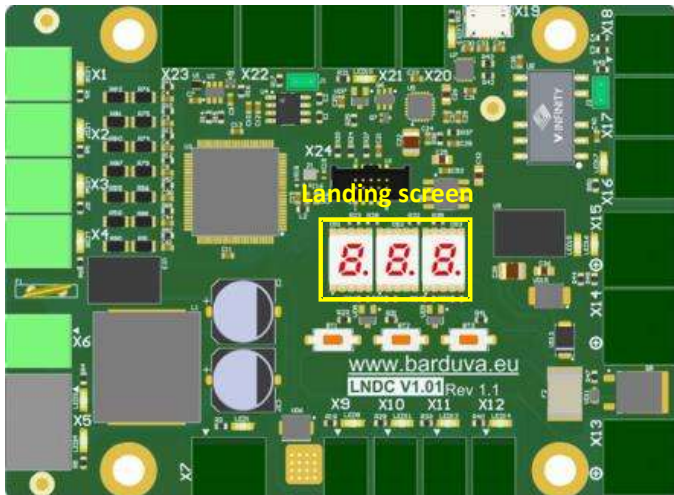

### 8.1. Landing height programming

Step	Job description
1	<p>A travel height of each landing must be saved in to a system memory. After assembly of the lift or after changing reference point position, also after replacement of the Base unit board there is required to perform programming of each landing except ground floor. Ground floor is always set at 0.00 mm height and must be set with reference switch.</p>
2	<p>Preparation for programming:</p> <ol style="list-style-type: none"> <li>1. make sure the reference switch SW07 and Lower limit switch SW03 on the same ramp are in right position. Platform stops in landing at ground floor;</li> <li>2. ensure the landing switch SWx1 is installed in each floor and corresponds right level where the platform should stop in landing;</li> <li>3. ensure door control board shows correct floor number.</li> </ol>
3	<p>Setting address of the door controller:</p> <ol style="list-style-type: none"> <li>1. Use configuration buttons BT1, BT3 and set up appropriate number on the control board inside of each door.</li> <li>2. Press button BT2 for no less than 10 seconds to apply the value to the control board.</li> </ol> <div data-bbox="491 990 1168 1482" data-label="Image">  </div> <p>Each door control board LNDC with version v1.01 or higher must have own unique address in the lift. This is like a number of floors where is used the control board.</p>
4	<p>Programming:</p> <ol style="list-style-type: none"> <li>1. switch operational mode from <i>Normal</i> to <i>Service / Maintenance</i>. Press and hold 2 sec. RED button SERV on the Base controller A5.</li> <li>2. move the platform to the requested landing, floor level. Use Black buttons UP and DOWN on the Base controller A5. Also it should be possible to manage the movement from the control operation panel on the platform by ground and next floor buttons;</li> <li>3. press STOP button BT11 on the control operation panel of the platform as soon as the platform is in appropriate landing level. Leave it in such state.</li> <li>4. press a call button on door frame for no less than 5 seconds and release it;</li> <li>5. press the call button for a moment. The call button should blink once in yellow;</li> <li>6. press the call button for no less than 10 seconds and release it;</li> <li>7. press the call button for a moment. The call button again should blink once in yellow;</li> </ol>

	<p>8. release the STOP button;</p> <p>9. program other floors. Repeat steps 2...8;</p> <p>10. move the platform to ground floor and stop it at level around 50 cm over ground landing level;</p> <p>11. restart the power fully (wait at least 10 seconds after turn OFF). Platform will run initialisation and calibration cycle itself, moves automatically down till the reference point which corresponds ground landing level;</p> <p>12. test memorised height levels in normal operation;</p> <p>13. repeat programming procedure if that would be necessary until wanted result will be achieved.</p>
--	---

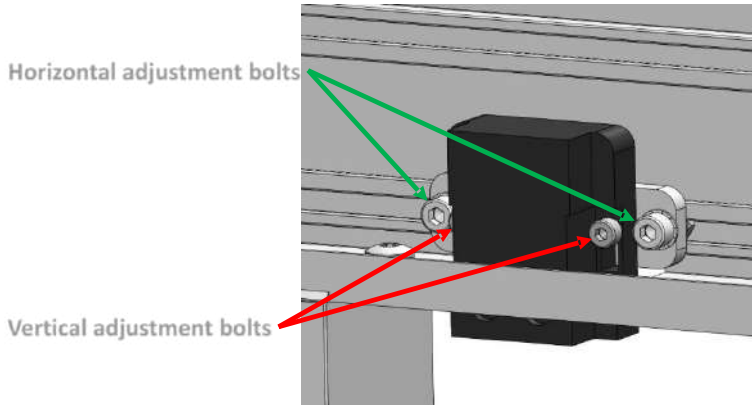
## 8.2. Door contact and lock latch adjustment

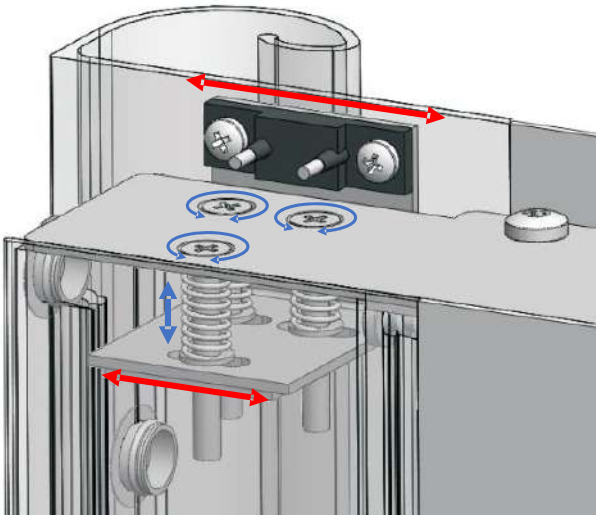
Step	Job description
1	Ensure that closed and locked door would play only a bit. There is recommended to achieve 1-3 mm free play result.
2	If the door is under power open and close the door to check if / when it is closed, the door should always touch the upright at the same place (to avoid variation in the latch position).
3	If the door is closed and the lock not under power, you should operate the lock using triangular key. While locking and unlocking, the lock must remain lightly and smoothly, and the bolt should move freely.
4	After door installation always adjust door contact and lock
5	<p>Door contact adjustment:</p> <p>a) Contact socket: Adjust socket position to fit perfect horizontal and vertical</p> <div style="text-align: center;">  <p>Pic 13.2</p> </div>
6	b) Bridge:

	<p>Vertical bridge adjustment</p> <p>Horizontally you can adjust and slide without releasing fixation bolts</p> 
	<p>Lock adjustment:</p> <p>a) Lock latch: untighten bolts and adjust position of whole lock unit to fit lock latch. It must move free without any resistance and when lock is powered don't touch latch cup on door. It must be ~1 mm clearance between lock latch and cup when lock unit is powered.</p> 
<p>7</p>	<p>b) Lock latch catcher (cup): For latch catching cup adjustment you must release bolts from side. When door is fully closed, latch should fit without any resistance. After adjustment don't forget tighten bolts. In cup there is always installed plastic ring, DON'T REMOVE IT. It must be always installed to avoid, too much free play.</p>

### 8.3. Hydraulic door closer adjustment

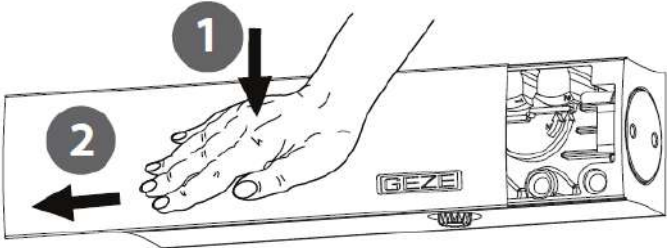
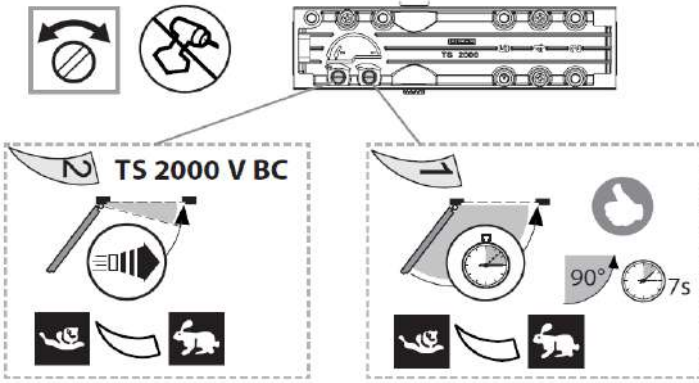
Step	Job description
1	<p>In SB200 we use GEZE hydraulic door closer. It is installed inside the door frame. To get access to it you shall open top door cover from inside the shaft. When you can reach it, remove cover as it is shown in the image.</p> 
2	<p>When cover from hydraulic closer are removed you can adjust closing and end soft closing speed. For this step you need slotted type screw driver. Do not use power tool.</p> 

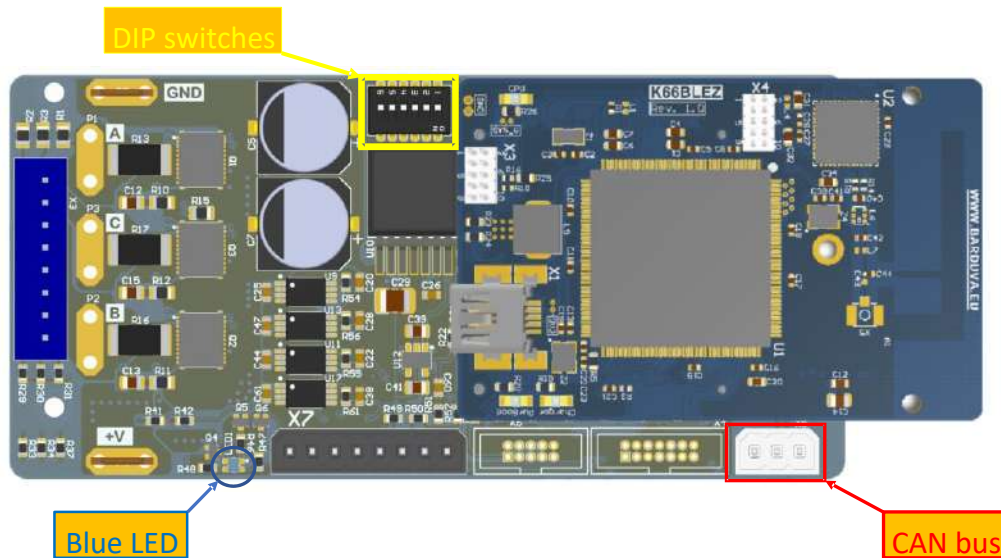

## 8.4. BAR Automatic door opener calibration (optional)

Step	Job description
1	<p>Steps for auto opener calibration with DIP switches:</p> <ol style="list-style-type: none"> <li>1. Power OFF DMC v.4.12 Unplug connector.</li> <li>2. Unplug CAN bus cable.</li> <li>3. Open door / gate manually.</li> <li>4. Power ON DMC v.4.12. Wait 10 seconds.</li> <li>5. Enter Calibration mode: Switch micro switch No.1 to opposite position (if is ON, switch it OFF and vice versa). Blue LED must start blinking on main opener / closer pcb.</li> <li>6. Save data of sloser door gate: manually close a door completely. Switch micro switch No.2 to opposite position. (if it is ON switch it OFF and vice versa).</li> <li>7. Save data of opened door at wanted position: manually open a door and leave it at required opened position. Switch micro switch No3 to position (if it is ON switch to OFF and vice versa).</li> <li>8. Exit from calibration mode: switch micro switch No1 back to position which was at the beginning. Flashing Blue LED must turn OFF. Calibration done.</li> <li>9. Power OFF DMC v4.12. Unplug connector.</li> <li>10. Close door / gate manually.</li> <li>11. Return switches 2 and 3 to their original positions.</li> <li>12. Ensure that all settings on dip switch are correct (meet floor number, suitable speed level). If auto opener was delivered fitted into a door just return micro switched to their original position as they were at the beginning.</li> <li>13. Plug in CAN bus cable.</li> <li>14. Power ON DMC v4.12. Wait 10 seconds.</li> <li>15. Check out operation. Press call button to open door / gate.</li> </ol>

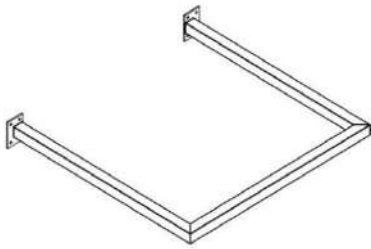

## 9. INSTALLATION OF REINFORCING BRACKET (OPTIONAL)

### 1. PACKAGE ITEMS\*

	Name	Shape	B-C(A)-D type Q'ty	A-B-C type Q'ty	Note
1.	Supporting ring <b>B-C(A)-D</b> or <b>A-B-C</b> type		1	1	Does not have fastening holes to the shaft. Holes shall be prepared at the site after ring fastening to the wall.
2.	Fixing Plate A		1	2	
3.	Fixing Plate B		1	2	
4.	Anchor 16		9	8	16 x 150 / 80 - M12

5.	Nut A		5	6	DIN 1587 M12
6.	Nut B		13	16	DIN 934 M12
7.	Nut C		2	2	DIN 985 M12
8.	Washer A		2	0	DIN 9021 A12
9.	Washer B		13	16	DIN 125 A12
10.	Threa-ded rod		2 m	2m	M12

\* - There are indicated quantity of the items for one supporting ring only. In case of two supporting rings everything will be in twice as many. In case of three will be thrice.

In non standard cases may be other types of supporting rings and quantity of items in a package.

## 2. GENERAL INFORMATION

### 2.1. Ring B-C(A)-D type. Door is at A(C) side

General view from the top.

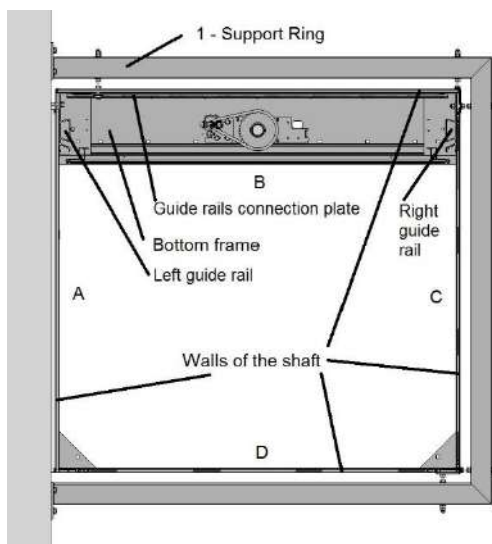

### 2.2. Fastening supporting ring to a wall

Find correct position out for the supporting ring just after guide rails have been fixed to the bottom frame and leveled. Align the ring with guide rails connection plate. Level the ring and fasten it with four anchors at both sides. Depending from a construction of building there may be needed another fastening way than shown. That shall be selected at the site.

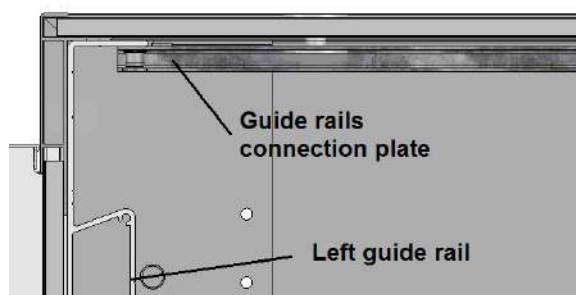
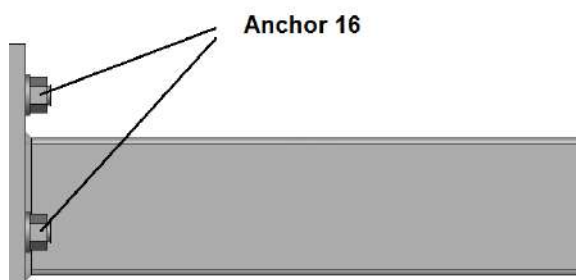

### 2.3. Fastening shaft. Sides B and C (A)

Assembly the shaft at B side. Fix corners profiles. Fix panels at B side until supporting ring level. Level the ring. Find correct position out of fixing plate B. Make two holes through supporting ring and one through guide rail from C (or A) side. Cut threaded rod off. Prepare two pieces of required length. Fasten the ring with the shaft.

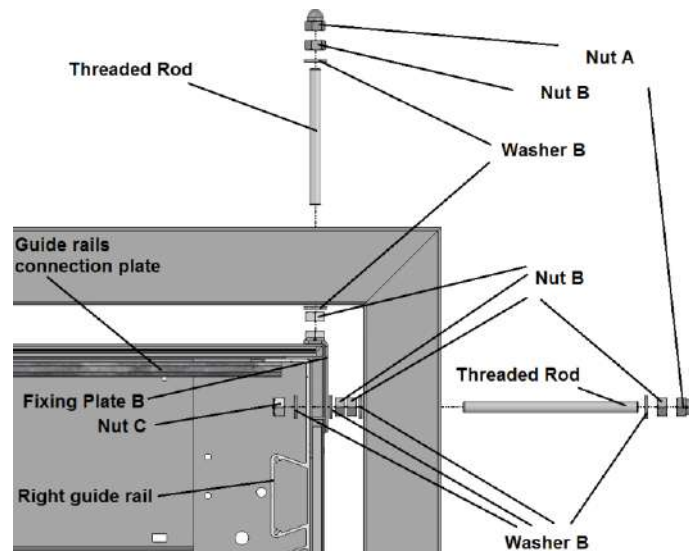

### 2.4. Fastening shaft B side and guide rail to a wall

Before fastening the shaft, in addition, there needs to make one hole through supporting ring and one through panel in the shaft with guide rails connection plate at once. Cut threaded rod off. Prepare one piece of required length. Fix B side. Then make one hole through the guide rail for fixing to a wall. Fix the guide rail.

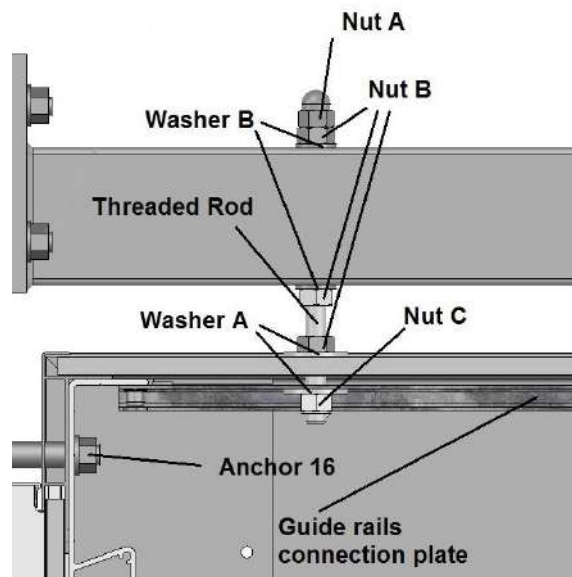

### 2.5. Fastening shaft. Sides C (A) and D

Assembly the shaft at C(A) and D sides. Fix corners profiles. Fix panels at C(A) and D sides until supporting ring level. Find correct position out of fixing plate A. Make two holes through supporting ring. There does not needed additional holes in the shaft. The ring supports the shaft in touch only. Cut threaded rod off. Prepare two pieces of required length. Adjust and fix Plate A.

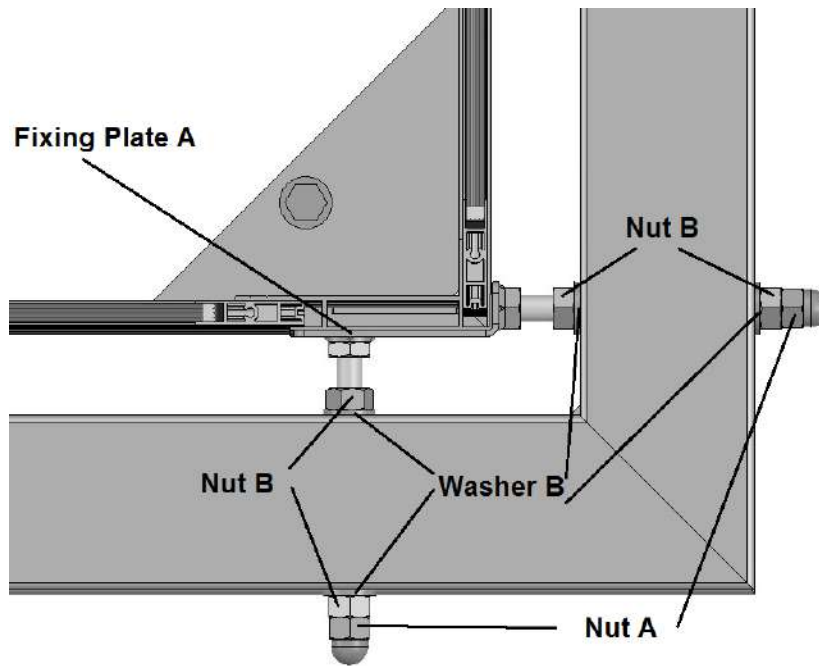

**2.6. Ring A-B-C type. Door is at D side**

General view from the top.

During its assembly follow the above recommendations for fastening supporting ring B-C(A)-D type.

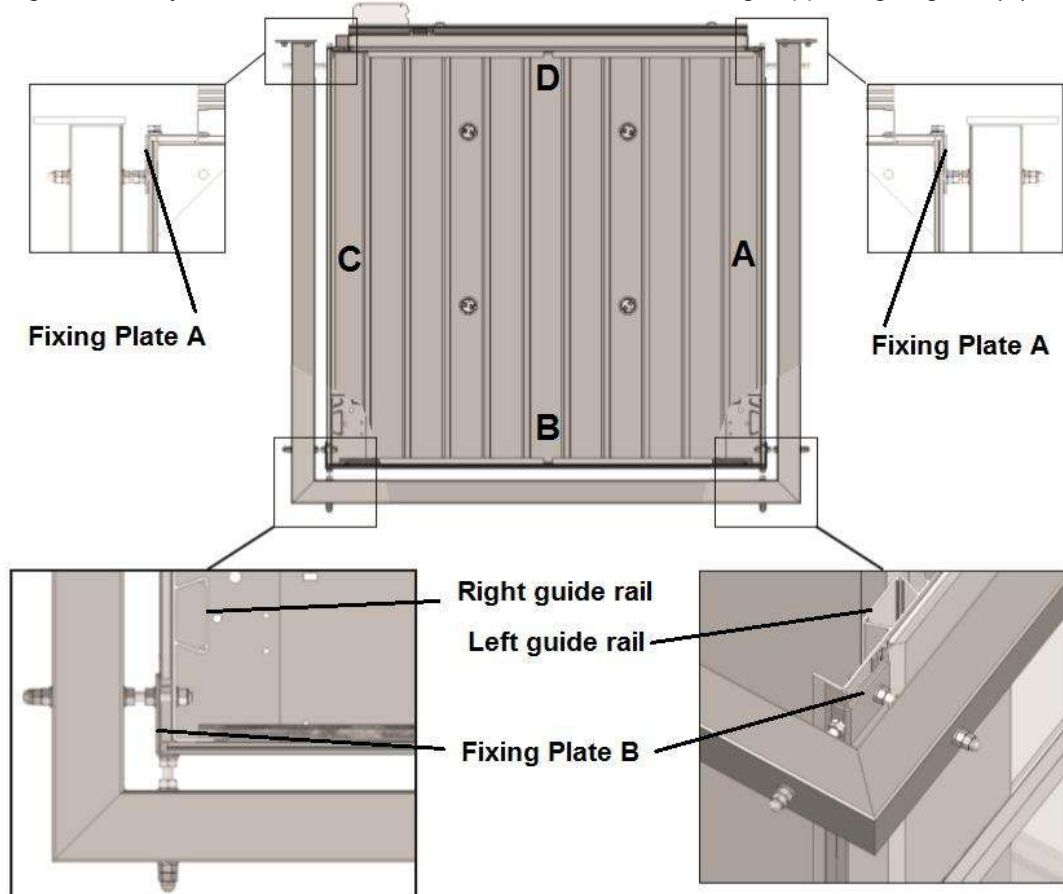

## 10. CHECKLIST

### Checklist after lift installation – AB300

Place: \_\_\_\_\_

Country:

Postal code

Town:

Street:

Serial number:

#### Lifting gear

	<i>Check mark</i>	<i>Remarks</i>
○ Belt condition	<input type="checkbox"/>	_____
○ Functioning of motor brake	<input type="checkbox"/>	_____
○ Functioning of motor	<input type="checkbox"/>	_____

#### Lift platform

○ Emergency light	<input type="checkbox"/>	_____
○ Emergency alarm	<input type="checkbox"/>	_____
○ Sensitive safety edge (control panel)	<input type="checkbox"/>	_____
○ Sensitive safety edges (platform floor)	<input type="checkbox"/>	_____
○ Battery	<input type="checkbox"/>	_____
○ Emergency stop	<input type="checkbox"/>	_____
○ Functioning of door opening zone devices	<input type="checkbox"/>	_____

#### Well

- Means of attachment  \_\_\_\_\_
- Over travel limit switch positions (adjusted)  \_\_\_\_\_
- Door opening zone plates  \_\_\_\_\_
- Emergency stop at shaft bottom  \_\_\_\_\_

**Doors**

- Door contacts  \_\_\_\_\_
- Closing functions  \_\_\_\_\_
- Locks  \_\_\_\_\_

**General function**

- Call buttons  \_\_\_\_\_
- Pit prop  \_\_\_\_\_
- Overload  \_\_\_\_\_
- Dynamic test (rated load + 10% kg.)  \_\_\_\_\_
- Static test (rated load + 25% kg.)  \_\_\_\_\_

**Remarks:**

Installation company:

--	--	--	--	--	--	--	--	--	--	--	--	--	--	--	--	--	--	--	--	--

Date: 

--	--	--	--	--	--	--	--

 Telephone: 

--	--	--	--	--	--	--	--	--	--	--	--	--	--	--	--	--	--

Installer: 

--	--	--	--	--	--	--	--	--	--	--	--	--	--	--	--	--	--	--	--	--

Signature:.....

Installer: 

--	--	--	--	--	--	--	--	--	--	--	--	--	--	--	--	--	--	--	--	--

Signature:.....

Installer: 

--	--	--	--	--	--	--	--	--	--	--	--	--	--	--	--	--	--	--	--	--

Signature:.....

**AB300**