

barduva 

# EMB100

Residential Compact Lift



MADE IN EU

# EMB100

## Residential Compact Lift

**EMB100** elevator is a great solution for people who have difficulty climbing stairs. Lightweight and with an aesthetic design, it will take up very little space in your home.

In fact, it will be almost invisible. Easy and quick installation will save you money and time, so you can use it the day after installation work. The platform is large enough to accommodate 2 persons.

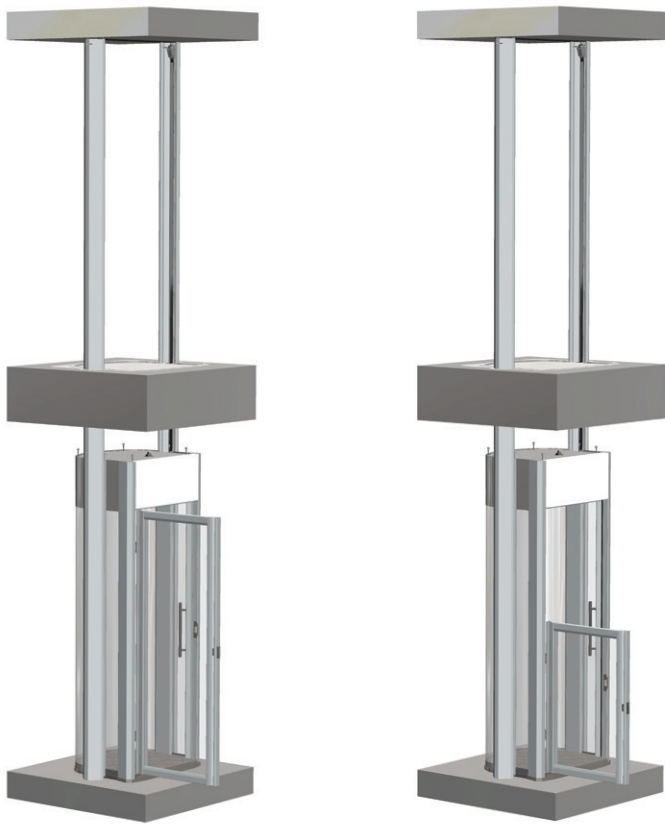

Shaft and door:

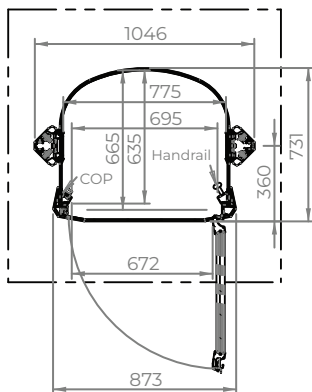

Floor cutout:

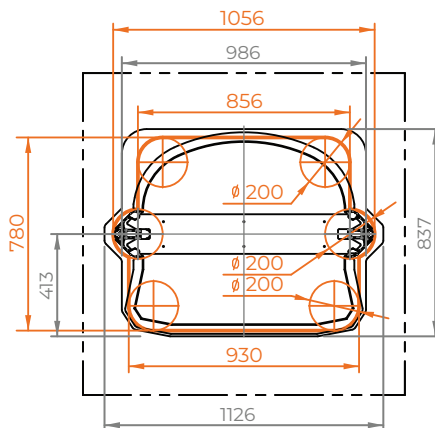

If you are looking for a **safe and convenient way to move between floors** in your home, the EMB100 lift can become an indispensable part of your daily life.

### EMB100 LIFT ADVANTAGES:

- Easy to install
- Does not require an elevator shaft
- Very safe
- Comfortable and stylish

#### Technical Specification

2 stops

Maximum travel height: 3000 mm

Minimum travel height: 2400 mm

Lower level minimum ceiling height: 2000 mm

Upper level ceiling minimum height: 2370 mm

Shaft dimension:

Width 1046 mm - Length 731 mm

Internal cabin width: 775 mm

Internal cabin length: 665 mm

Internal cabin height: 1920 mm

Door: 1920 mm height, 672 mm width

Gate: 1100 mm (with safety sensor)

No pit. Platform thickness: 65 mm

Control panel:  
- Up button  
- Emergency button  
- Alarm button  
- Down button  
- 2 remote controllers

Load capacity: 170 Kg / 2 persons

Belt driven system

Aluminium guide rails

Wall sides from plexiglass

Safety system:  
- Over weight sensor  
- Safety bottom plate  
- Belts tension sensor

Options:  
- RAL color  
- Floor indicator  
- Drop Seat  
- Auto dialer 2N  
- GSM (4G) 2N

**Barduva, JSC**  
Beržuonos str. 2, LT-02121 Vilnius, Lithuania  
00 370 5 231 0770 (Phone)  
sales@barduva.eu  
[www.barduva.eu](http://www.barduva.eu)