

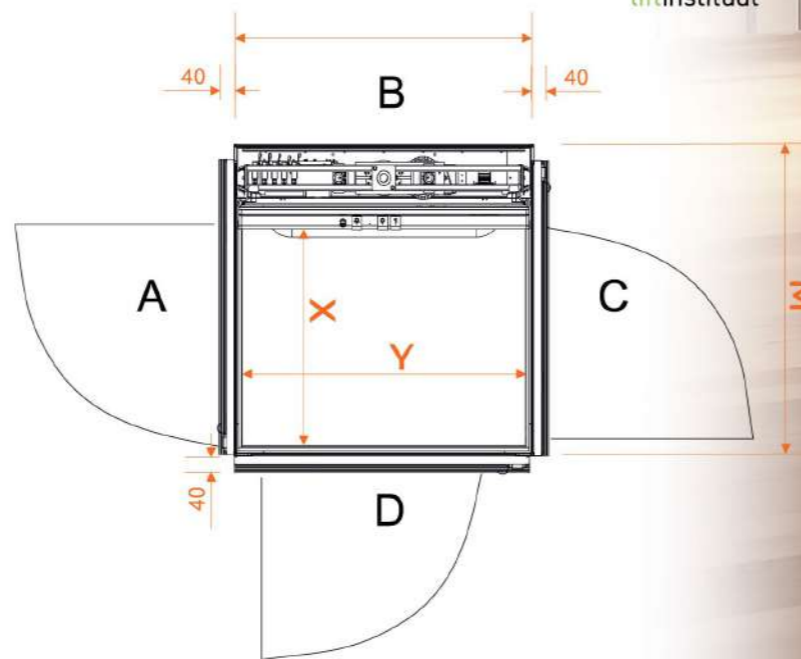

Drive system	Two Polyurethane timing belts
Nominal load	450 kg / 5 persons
Lifting speed	0.15 m/sec (9 m/min)
Travel height	Up to 20 meters
Min. headroom	2400 mm
Machine room	Machine room less (MRL)
Landings (floors)	Up to 6
Pit (or ramp)	50 mm
Platform dimensions* (length x width) (X x Y)	Shaft dimensions* (length x width) (M x N)
1140 x 1480 mm	1530 x 1530 mm
1064 x 1480 mm	1454 x 1530 mm
1100 x 1400 mm	1490 x 1450 mm
1064 x 1400 mm	1454 x 1450 mm
<small>*customized dimensions available</small>	<small>*customized dimensions available</small>
Dimensions of the doors* (width x height, mm)	940 x 2000 mm
<small>*customized dimensions available</small>	
Configuration of the doors	Single hinged door (L/R) or double swing doors. Up to 3 doors per floor, single entry, open through or adjacent access
Shaft walls	Sandwich or tempered glass panels (4 mm + 0.76 PVB foil + 4 mm)
Standard color	RAL 9006 (light grey aluminum)
Other colors	According RAL palette
Soft START/STOP	Standard equipment
Power supply	220-230 V, 1 Ph, 16A / 380-400 V 3 Ph, 10A, 50 or 60 Hz
Motor	Less than 55 dB
Control system	Micro controller

Safety equipment:
Protective edge around the platform, emergency braking buttons inside the platform and in the shaft, emergency stop switches, electronic speed control, overload detectors, door opening and lock control, belt sensors, electronic motor management

Conformity of the European Standard:
MD2006/42/EC, EN81-41: 2010, EN 81-20:2020



AB300 Home Lift



Barduva, JSC
Beržuonos str. 2, LT-02121 Vilnius, Lithuania
00 370 5 231 0770 (Phone)
sales@barduva.eu
www.barduva.eu

MADE IN EU

AB300

Home Lift



AB300 is a belt driven vertical platform lift assembled using high quality materials and designed to meet the characteristics of ultimate performance and outstanding aesthetics. It is designed to be used in private houses, cottages and apartment buildings.

AB300 can be installed into existing shaft or its own shaft which is constructed with aluminium profiles structure and sandwich panels or glass panels.

A maximum of three doors may be installed on each floor with either left or right swing, or double swing door.



AB300 drive unit works extremely silent. That is because we use belt drive system.

A uniformly backlit control panel, with a comfortable handle below, contains large buttons with embossed symbols at a convenient height for accessing from sitting or standing positions.

A backup power source ensures that the elevator can be used to evacuate people from it, in the event of a power outage.

Personalized lifting solution with a wide variety of accessories and options such as: different lightning, automatic door openers, silent door locks, etc.

AB300 IS AN EXTREMELY SILENT LIFT. IT WILL ADVANCE YOUR HOME AND MAKE DAILY LIFE ENJOYABLE!

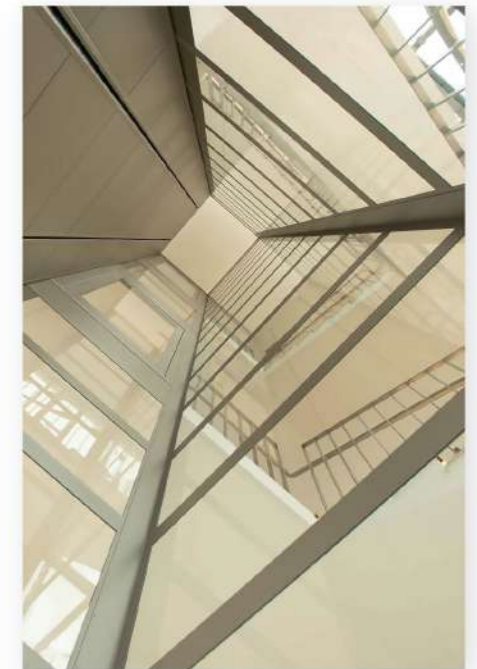

To meet the characteristics of performance and aesthetics:



LED light wall panel.

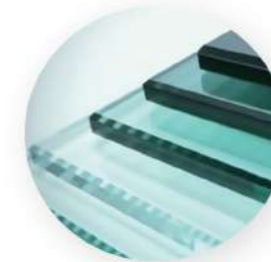

Standard glass or tinted or steel sandwich panels.



The lift can be painted in any RAL colors.



Integrated overspeed sensors, falling arrestor and belt tension/rupture sensors.



Belt driven vertical platform lift. Extremely silent.

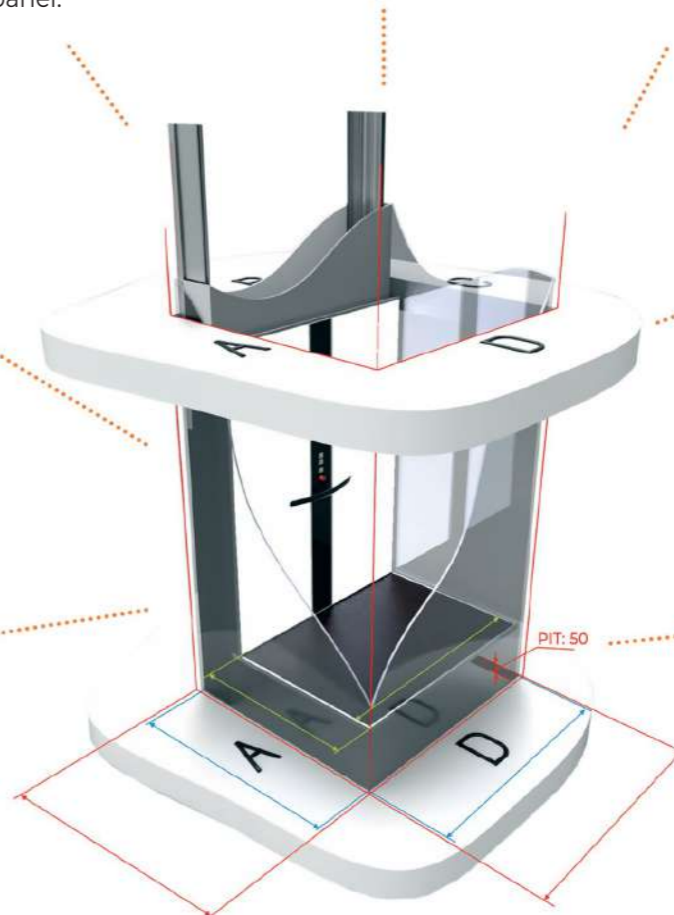

High quality design and materials.



Lift platform floor can be covered with different color rubber or vinyl.